

ZAXIS-3 series

HITACHI

ZAXIS
850
850LC
870H
870LCH



HYDRAULIC EXCAVATOR

- **Model Code** : ZX850-3 / ZX850LC-3 / ZX870H-3 / ZX870LCH-3
- **Engine Rated Power** : 397 kW (532 HP)
- **Operating Weight** : ZX850-3 : 80 500 kg / ZX850LC-3 : 82 200 kg
ZX870H-3 : 82 100 kg / ZX870LCH-3 : 84 000 kg
- **Backhoe Bucket** : SAE, PCSA Heaped : ZX850-3 / ZX850LC-3 /
ZX870H-3 / ZX870LCH-3 : 2.9 - 4.5 m³
CECE Heaped : ZX850-3 / ZX850LC-3 / ZX870H-3 /
ZX870LCH-3 : 2.6 - 3.9 m³
- **Loading Shovel Bucket** : SAE, PCSA Heaped :
ZX850-3 / ZX870H-3 : 3.6 - 4.4 m³

The New Generation Hydraulic Excavators

The HITACHI ZAXIS-3 series new-generation hydraulic excavators are packed with a host of technological features - clean engine, HITACHI advanced hydraulic technologies, with strong undercarriage and front attachment, plus well matching of power and speed.

The ZAXIS-3 series can get the job done with proven productivity, durability, and reliability, especially in heavy-duty excavation and quarry operations.

- Clean engine complies with the emission regulations US EPA Tier 3 and EU Stage III A
- The advanced low noise design complies with the coming EU noise regulation 2000 / 14 / EC, STAGE II



Productivity

- Increased digging force
- Enhanced boom recirculation system
- Boom mode selector
- Larger-diameter front piping
- Combined operation of boom and arm
- New bucket regenerative system
- High power yet low fuel consumption
- Common rail type fuel injection system
- Cooled EGR system

Page 4-5

Durability and reliability

- Increased loading capacity of swing circle
- Enlarged upper and lower rollers, idlers and sprockets
- Strengthened track links
- Pressed master pins
- Strengthened idler pedestal
- Strengthened idler bracket
- Full track guard provided standard (ZAXIS 870H / 870LCH)
- Enlarged pins
- Strengthened arm and boom
- Strengthened general-purpose bucket
- Strengthened H-bucket for heavy-duty

Page 6-7

Operator comfort

- Good visibility from inside cab
- Short stroke levers
- Wide foot space
- Comfort designed seat
- Improved controllability and operator comfort

Page 8-9

Multi function monitor

- Maintenance support
- Attachment support system
- Multi-language selection
- Rear view camera (optional)
- Theft deterrent system
- Fuel consumption monitoring

Page 10-11

Maintenance

- Parallel arrangement of the cooling pack
- Conveniently located inspection points
- Extended maintenance intervals

Page 12-13

Safety measures

- CRES II cab (ZAXIS 850 / 850LC is standard equipped)
- H/R cab (ZAXIS 870H / 870LCH is standard equipped)
- Cab right guard
- Evacuation hammer
- Pilot control shut-off lever

Page 14

Environment measures

- A cleaner machine
- A quieter machine
- A recyclable machine

Page 15

Parts & service

Page 16-17

Specifications

Page 18-35



Notes : Some of the pictures in this catalog show an unmanned machine with attachments in an operating position. These were taken for demonstration purposes only and the actions shown are not recommended under normal operating conditions.

World-Class Productivity

To yield high production yet maintain low fuel consumption, such was the objective of the development of a new engine and hydraulic system for the ZAXIS 850 / 850LC / 870H / 870LCH.

Production: Approx. 7 % Increase

(vs. Conventional Model)



Advanced Hydraulic Technologies

Increased Digging Force

14 % more bucket digging force and 8 % more arm digging force.
(At power boost mode)
(vs. Conventional Model)

Enhanced Boom Recirculation System

In combined operation of boom lower and arm, arm speed can be increased by approximately 15 % over the conventional. Pressurized oil from boom cylinder bottom side is delivered to boom cylinder rod side to lower the boom, assisted by boom weight. Conventionally, pressurized oil from pump is delivered to boom cylinder rod side to lower the boom. The new system also allows an efficient combined operation of swing and lowering the boom.

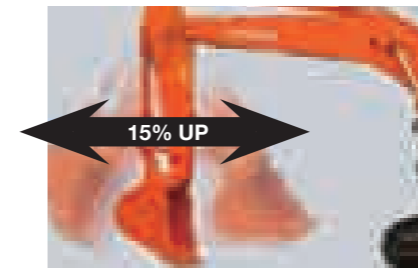

Boom Mode Selector

The amount the body can be lifted or pulled by the front of machine can be ON or OFF selected. This helps to provide for more comfortable operation and contributes to longer component service life.

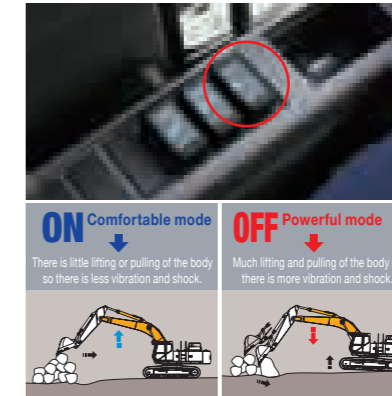

Larger-Diameter Front Piping

Arm piping is increased in diameter to reduce hydraulic loss (theoretically 8 %) for speedy front operation.

Combined Operation of Boom and Arm

In combined operation of swing + boom lower + arm roll-out, or in leveling (boom lower + arm roll-out), arm roll-out speed can be increased greatly. Here's why. A variable throttle, provided in the arm circuit, adjusts the flow when needed to reduce hydraulic loss in combined operation with arm roll-out.

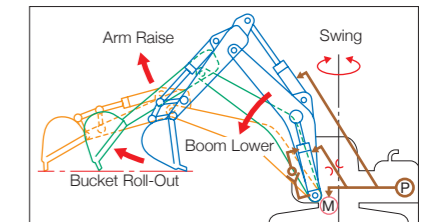

New Bucket Regenerative System

Swift bucket actions can be done in combined operation for excavation through the new bucket regenerative circuit. When the load to the bucket is light, pressurized oil from bucket cylinder rod side is delivered through a regenerative valve to bucket cylinder bottom side for the effective use of hydraulic energy.

Development Concept of New Engine

High Power Yet Low Fuel Consumption

10 % Increase in output
(vs. Conventional Model)
● 397 kW (532 HP) / 1 800 min⁻¹

The new clean engine, complying with the emission regulations Tier 3 in US (EPA) and EU Stage III, can reduce fuel costs by electronic control.

Common Rail Type Fuel Injection System

Electronic control common rail type fuel injection system drives an integrated fuel pump at an ultrahigh pressure to distribute fuel to each injector per cylinder through a common rail. This enables optimum combustion to generate big horsepower, and reduce PM* and fuel consumption.

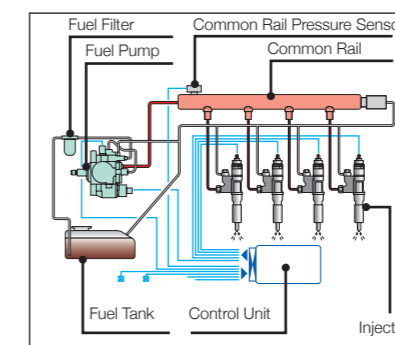

Cooled EGR** System

Exhaust gas is partially mixed with intake air to lower combustion temperature for reducing NOx and fuel consumption. What's more, the EGR cooler cools down exhaust gas to increase air concentration for complete combustion, reducing PM*.

*Particulate Matter
**Exhaust Gas Recirculation

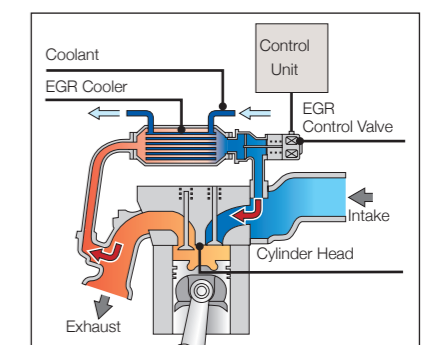

A Solid Base for a Long Life

Strengthened undercarriage for higher durability even in heavy-duty applications.



Strengthened Undercarriage

Increased Loading Capacity of Swing Bearing

The number of ball bearings in the swing circle, which sustains the upperstructure, is increased to boost the loading capacity of the swing circle by approximately 12 %, allowing stable swing even in tough operation. (vs. Conventional Model)

Pressed Master Pins

The master pin of each track link is pressed, instead of master pin using a pin retention to avoid disengagement.



Strengthened Upper Roller Bracket

The upper roller bracket wall thickness is increased for higher strength.



Enlarged Upper and Lower Rollers, Idlers and Sprockets

Upper and lower rollers are widened to increase contact areas, and idlers and sprockets are increased in diameter for more durability and mobility.

Strengthened Idler Pedestal

The bearing length of the idler pedestal is extended by approximately 54 % to increase durability and service life. (vs. Conventional Model)



Full Track Guard Provided Standard (ZAXIS 870H / 870LCH)

On the H-specification machines, full track guards are provided standard. Full track guards protect track links and lower rollers from damage and deformation. Moreover, they also keep out stones, preventing the overload to the undercarriage to reduce wear and damage.

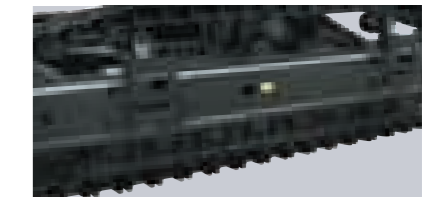

Strengthened Track Links

The boss diameter of each track link is increased by approximately 10 %. The thickness of each track link is also increased by approximately 65 %. Thickened track links extend service life. (vs. Conventional Model)



Strengthened Idler Bracket

The idler bracket is thickened for rigidity to prevent deformation and increase durability.

Strengthened Front Components

Enlarged Pins

Pins, used throughout the front attachment, are increased in diameter for strengthening.



Strengthened Arm and Boom

The arm and boom are strengthened by thickening and using stronger material.

Strengthened H-Bucket for Heavy-Duty

The heavy-duty bucket is reshaped, and bucket parts are strengthened to increase durability.

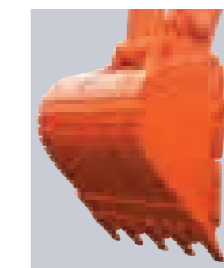

Strengthened General-Purpose Bucket

Bucket teeth are reshaped as Super-V teeth for smooth penetration and higher production.

Bushings are utilized at both ends of a bucket pin to eliminate clearances, preventing jerky operation.

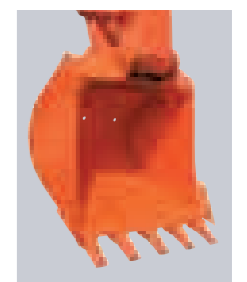

A New Standard in Operator Comfort

The operator's seat of the ZAXIS-3 series gives the operator an excellent view of the jobsite. On the widescreen colour LCD monitor the operator can see what is behind the machine. Ample legroom, short stroke levers and a large seat ensure optimum working conditions for the operator during long hours.



The ZAXIS-3 series cab has been redesigned to meet demands of customers. From the operator's seat the operator has an excellent view of the jobsite. On the widescreen color LCD monitor the operator can see machine conditions and with the rear view camera (optional), what is behind the machine. Ample legroom, short stroke levers and a suspension seat ensure optimum working conditions. The seat features horizontal, vertical adjustments and has a backrest contoured for comfort, with a HITACHI logo.

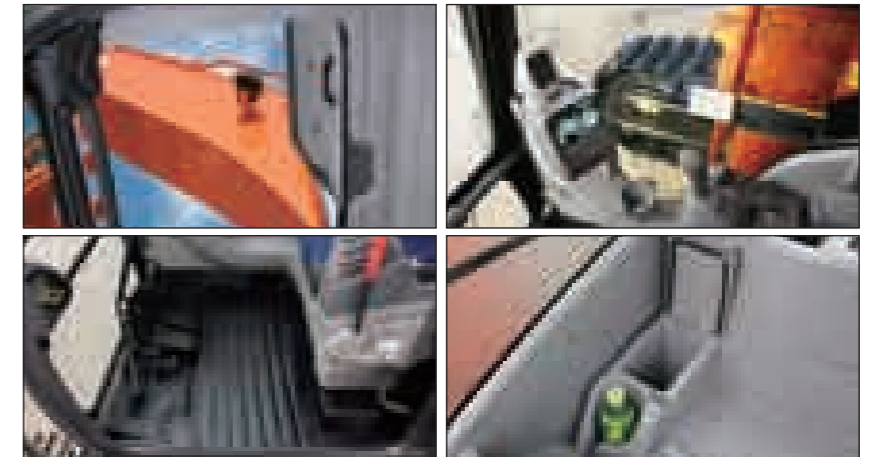

Wide adjustable armrests and a retractable seat belt are included. Short stroke levers allow for continuous operation with less fatigue. The cab is pressurized to keep out dust. Noise and vibrations are kept to a minimum due to the elastic mounts, filled with silicone oil, the cab rests on.

Visibility is improved especially for the right downward view. Sliding windows on the front (ZAXIS 850 / 850LC) and side enable direct communication between operator and other workers. Foot space has increased and travel pedals have been redesigned for easier operation.

A flat floor allows for easy cleaning. Ergonomic controls and switches, fully automatic air conditioner and a radio complete the package.



Embedded Information Technology

The ZAXIS-3 series is equipped with a widescreen color LCD monitor with adjustable contrast for day and night shifts. With the monitor the operator can check maintenance intervals, select work modes, monitor fuel consumption, and connect to the rear view camera (optional). A theft deterrent system and multi-language selection is also available.

Multi function monitor

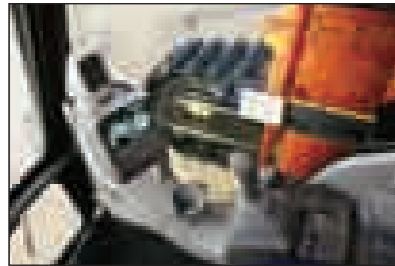

The color LCD monitor, located in the cab, indicates coolant temperature, fuel level, and maintenance data. It also allows one-touch adjustment of the attachment. The display can also be adjusted to day or night shift.

Attachment support system (work mode selector)

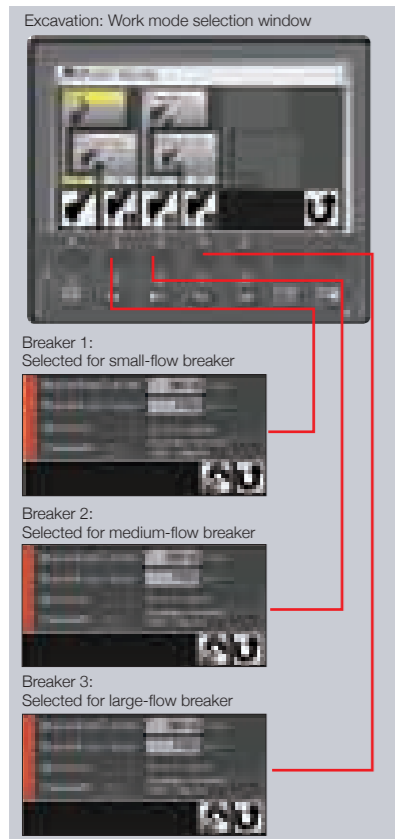

The work mode can be selected from the multi-function monitor inside the cab. Pump flow in the selected work mode can be monitored.

Maintenance support



Replacement timing of hydraulic oil and fuel filters is alerted to the operator through the LCD monitor according to the schedule preset by the user each time when turning the key switch. The scheduled maintenance can prevent the failure of the machine.

Multi-language selection

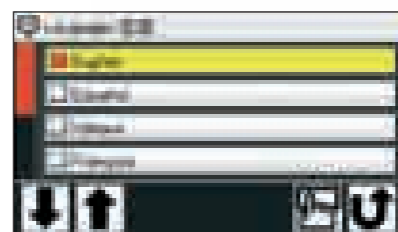

The menu allows selection from 12 languages.



Theft deterrent system



The electronic immobiliser requires the entry of an encryption code to the multifunctional monitor each time when starting the engine to prevent theft and vandalism.

Rear view camera (optional)



The widescreen color LCD, teamed up with the rear view camera on the counterweight, gives the operator unobstructed rearward viewing. The rear view camera automatically works when traveling, and can also be manually turned on with a select switch on the monitor.

Fuel consumption monitoring

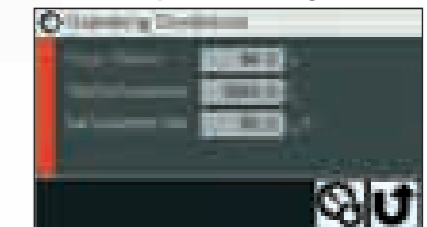

Fuel consumption per operating hour is computed, and the result is displayed on the LCD monitor. This information suggests refuelling timing, and guides energy-saving operation and efficient job management.

Simplified Maintenance

Focusing on simplified maintenance, including easy inspection, service and cleaning.



Parallel Arrangement of the Cooling Pack

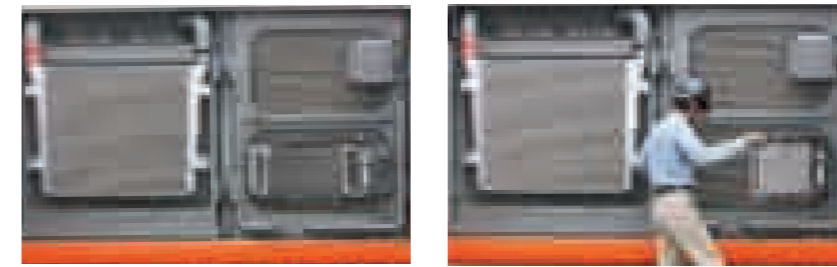

The radiator and oil cooler are separately laid out in a parallel for easy demounting, instead of the conventional in-line arrangement. This new parallel arrangement significantly helps facilitate cleaning around the radiator and oil cooler, and improving oil cooling capability. The air-conditioner condenser and fuel cooler can be opened to easily clean them and the radiator located behind.

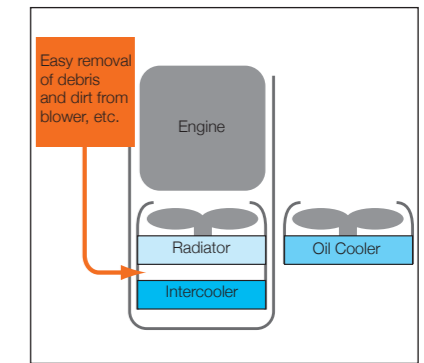

Conveniently Located Inspection Points



In addition to a pre-filter, dual main fuel filters are provided standard to reduce clogging of the fuel line to the engine. The engine oil pan is fitted with a drain coupler. When draining, an associated drain hose is connected to the drain coupler. The drain coupler is reliable, avoiding oil leakage and vandalism. The sidewalk is widened from 340 mm (Conventional model) to 510 mm for smooth walking from cab to rear. The sidewalk is the field-proven split type that permits the detaching of its rear when traveling or operating on rough terrain.

The fresh air filter for the air conditioner is relocated to cab door side from conventional location behind the operator seat. This allows easy cleaning and replacement of the fresh air filter, like the air circulation filter inside the cab.

Extended Maintenance Intervals

Automatic Lubrication (Optional) / Repositioned Bucket Lubricating Points

The front attachment is automatically lubricated (When optional auto-grease lubricator is equipped), except for bucket lubricating points at the top of arm that are repositioned for side lubrication.

Enlarged Fuel Tank

The fuel tank is enlarged, increasing the capacity from 900 liters (Conventional model) to 1 120 liters. Refueling intervals (when filled fully) extend from 17 to 18 hours.

Extended Hydraulic Oil Filter Change Intervals

Hydraulic oil filter change intervals are extended from 500 hours (Conventional model) to 1 000 hours to help reduce running costs.

Safety Features

An array of safety devices for enhanced safety.



Protecting the Operator From Tipping Accident

CRES II Cab
(ZAXIS 850 / 850LC are standard equipped)

The CRES II cab is designed to help with "just in case" protection for the operator. Safety in case of tipping is improved. The cab top can withstand four-fold loading.



H/R Cab
(ZAXIS 870H / 870LCH are standard equipped)

The H/R cab utilizes the reinforced front window and FOPS* at the roof for protection against falling objects. The front glass window, straight-laminated type, is fixed to shut out dirt and debris. The cab provided with a full guard satisfies the OPG**(Level II) cab requirements stipulated by ISO.

*Falling Object Protective Structure
**Operator Protective Guards



Additional Features

Cab Right Guard

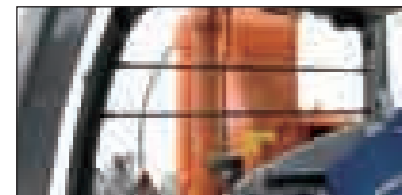

Evacuation Hammer

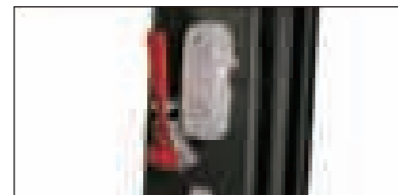

Pilot Control Shut-Off Lever



Other features include a retractable seatbelt, evacuation hammer and emergency engine shut-off switch. A shut-off lever for pilot control helps to prevent unintentional movements.

Environmental Features

Boarding a clean engine complying with the rigorous emission regulations.



A Cleaner Machine

The ZAXIS-3 series is equipped with a clean but powerful engine to comply with Tier 3, and Stage III A. An engine emission regulations effective in the U.S. EPA and European Union from 2006. Exhaust gas is partly re-combusted to reduce particulate matter (PM) output and lower nitrogen oxide (NOx) levels.

A Quieter Machine

Engine noise is reduced by approximately 2 dB with the robust engine. The engine cooling fan is a large 120 mm diameter variable-speed electro-hydraulic fan. This fan automatically starts when temperature comes into the high temperature range, ensuring low noise operation. A proven large muffler is provided to reduce sound and exhaust emissions greatly.

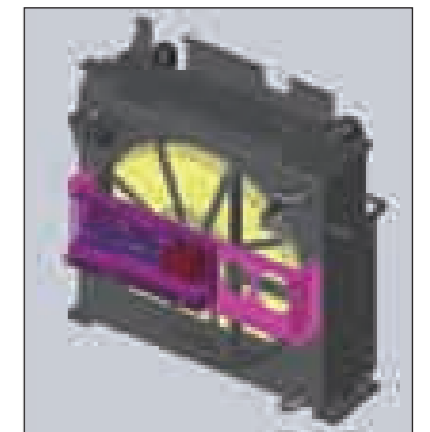

A Recyclable Machine

Over 97 % of the ZAXIS-3 series can be recycled. All resin parts are marked to facilitate recycling. The machine is completely lead-free. The radiator and oil cooler are made from aluminium and all wires are lead-less. In addition, biodegradable hydraulic oil is available for jobsites where special environmental care is required.



Parts & Service

Over the years, we have gained experience in one of the most competitive service markets in the world - Japan.

Using our know-how in dealing directly with customers, we have created a worldwide support system that is highly capable.



Machine includes optional equipment installed by customer.

Parts

HITACHI only offers genuine high quality parts. We guarantee that these parts have high performance and long life. We manage around 1 000 000 types of parts all around the world. They are designed and built to be the best match for your HITACHI equipment. HITACHI has a global parts distribution network that makes sure you get what you need as quickly as possible. We have more than 150 dealers worldwide who provide the closest support for your needs. In most cases, your dealer will have the replacement part that you require. If a dealer does not have a certain part, he can order it from four fully stocked parts depots located across the world. These distribution centers are all connected by a on-line system that gives them access to shared information on stocks, such as the number and type of available parts. The depots, which in turn are stocked by a parts center in Japan, minimize delivery time and enable you to get your parts as efficiently and quickly as possible.



Service

Our goal is to "keep customer equipment at a maximum performance level". To fulfil this goal, we have set more than 150 dealers all over the world. They have highly trained technicians, and provide a number of support programs. HITACHI provides a unique extended warranty program called HITACHI Extended Life Program, or HELP.

To minimize downtime during troubleshooting, we developed a PDA based diagnostic system called "Dr.ZX". To keep our customers' equipment in top running shape, good service is indispensable. We believe personnel training is the key to providing the best service.

If you would like more information regarding parts and/or service, please ask your nearest HITACHI dealer. Not all programs and/or services are available in every market or region.

SPECIFICATIONS

ZX870H-3 / ZX870LCH-3

ENGINE

Model.....	Isuzu AH-6WG1XYSA-03
Type	4-cycle water-cooled, direct injection
Aspiration.....	Turbocharged
No. of cylinders	6
Rated power	
ISO 9249, net.....	H/P mode :
(Without Fan)	397 kW (532 HP) at 1 800 min ⁻¹ (rpm)
EEC 80/1269, net ...	H/P mode :
(Without Fan)	397 kW (532 HP) at 1 800 min ⁻¹ (rpm)
SAE J1349, net.....	H/P mode :
(Without Fan)	397 kW (532 HP) at 1 800 min ⁻¹ (rpm)
Maximum torque	2 250 Nm (229 kgf m) at 1 600 min ⁻¹ (rpm)
Piston displacement....	15.681 L
Bore and stroke.....	147 mm x 154 mm
Batteries.....	2 x 12 V / 170 Ah

HYDRAULIC SYSTEM

- Work mode selector
 - General purpose mode / Attachment mode
 - Engine speed sensing system
- Main pumps 2 variable displacement axial piston pumps
- Maximum oil flow... 2 x 528 L/min
- Pilot pump..... 1 gear pump
- Maximum oil flow... 30 L/min

Hydraulic Motors

- Travel 2 axial piston motors with parking brake
- Swing..... 2 axial piston motors

Relief Valve Settings

Implement circuit.....	31.9 MPa (325 kgf/cm ²)
Swing circuit.....	28.4 MPa (290 kgf/cm ²)
Travel circuit	34.3 MPa (350 kgf/cm ²)
Pilot circuit	3.9 MPa (40 kgf/cm ²)
Power boost	34.3 MPa (350 kgf/cm ²)

Hydraulic Cylinders

High-strength piston rods and tubes. Cylinder cushion mechanisms provided in boom and arm cylinders to absorb shock at stroke ends.

Dimensions

	Quantity	Bore	Rod diameter
Boom	2	215 mm	150 mm
Arm	1	225 mm	160 mm
Bucket	1	200 mm	140 mm
Bucket (BE)	1	215 mm	150 mm

Hydraulic Filters

Hydraulic circuits use high-quality hydraulic filters. A suction filter is incorporated in the suction line, and full-flow filters in the return line and swing/travel motor drain lines.

CONTROLS

Pilot controls. Hitachi's original shock less valve and quick warm-up system built in the pilot circuit.

- Implement levers 2
- Travel levers with pedals
- 2

UPPERSTRUCTURE

Revolving Frame

Welded sturdy box construction, using heavy-gauge steel plates for ruggedness. D-section frame for resistance to deformation.

Swing Device

Axial piston motor with planetary reduction gear is bathed in oil. Swing circle is single-row, shear-type ball bearing with inductionhardened internal gear. Internal gear and pinion gear are immersed in lubricant. Swing parking brake is spring-set/hydraulic-released disc type.

Swing speed 7.3 min⁻¹ (rpm)

Operator's Cab

Independent spacious cab, 1 005 mm wide by 1 795 mm high, conforming to ISO* Standards. (OPG top guard fitted Level II, ISO 10262 compliant cab) Reinforced glass windows on 4 sides for visibility. Reclining seat with armrests; adjustable with or without control levers.

* International Standardization Organization

UNDERCARRIAGE

Tracks

Tractor-type undercarriage. Welded track frame using selected materials. Side frame bolted to track frame. Lubricated track rollers, idlers, and sprockets with floating seals.

Track shoes with double grousers made of induction-hardened rolled alloy. Heat-treated connecting pins with dirt seals. Hydraulic (grease) track adjusters with shock-absorbing recoil springs.

Numbers of Rollers and Shoes on Each Side

Upper rollers.....	3
Lower rollers.....	8 : ZX870H-3
	9 : ZX870LCH-3
Track shoes.....	47 : ZX870H-3
	51 : ZX870LCH-3
Full length track guard	1

Travel Device

Each track driven by axial piston motor through reduction gear for counterrotation of the tracks. Sprockets are replaceable. Parking brake is spring-set/hydraulic-released disc type.

Automatic transmission system: High-Low.

Travel speeds	High : 0 to 4.1 km/h
	Low : 0 to 3.1 km/h

Maximum traction force.... 560 kN (57 100 kgf)

Gradeability 70 % (35 degree) continuous

WEIGHTS AND GROUND PRESSURE

ZX870H-3 :

Equipped with 8.4 m H-boom, 3.7 m H-arm and 3.5 m³ rock bucket (SAE, PCSA heaped).

Shoe type	Shoe width	Operating weight	Ground pressure
Double grouser	650 mm	82 100 kg	131 kPa (1.33 kg/cm ²)

Equipped with 7.1 m BE-boom, 2.95 m BE-arm and 4.3 m³ rock bucket (SAE, PCSA heaped).

Shoe type	Shoe width	Operating weight	Ground pressure
Double grouser	650 mm	82 400 kg	131 kPa (1.33 kg/cm ²)

Equipped with 7.1 m BE-boom, 3.7 m H-arm and 3.7 m³ rock bucket (SAE, PCSA heaped).

Shoe type	Shoe width	Operating weight	Ground pressure
Double grouser	650 mm	81 700 kg	130 kPa (1.32 kg/cm ²)

BACKHOE ATTACHMENTS

Boom and arms are of all-welded, box-section design. A number of booms and arms are available. Bucket is of all-welded, high strength steel structure. The ZAXIS 870H / 870LCH are a heavy duty type and can be equipped with a reinforced H-boom or BE-boom and H-arm or BE-arm.

Backhoe Buckets

ZX870H-3 / ZX870LCH-3

Capacity		Width		No. of teeth	Weight	Recommendation		
SAE, PCSA heaped	CECE heaped	Without side cutters	With side cutters			ZX870H-3 / ZX870LCH-3		
				7.1 m BE-boom		8.4 m H-boom		
				2.95 m BE-arm	3.7 m H-arm	3.7 m H-arm		
*1 3.50 m ³	3.10 m ³	1 870 mm	1 890 mm	5	3 790 kg	X	●	●
*1 3.70 m ³	3.20 m ³	1 950 mm	1 970 mm	5	3 900 kg	X	●	—
*1 4.30 m ³	3.80 m ³	2 090 mm	2 110 mm	5	4 270 kg	●	X	X
*1 1.90 m ³	1.70 m ³	—	1 490 mm	3	4 200 kg	X	●	●
*2 2.20 m ³	2.00 m ³	—	1 580 mm	3	4 400 kg	●	X	X
One-point ripper				1	2 680 kg	●	●	●
Applicable shoe type						650 mm Double grouser		650 mm Double grouser

*1 Rock bucket

*2 Ripper bucket

● Heavy-duty service

— Not applicable

X Can't installed

ZX870LCH-3 :

Equipped with 8.4 m H-boom, 3.7 m H-arm and 3.5 m³ rock bucket (SAE, PCSA heaped).

Shoe type	Shoe width	Operating weight	Ground pressure
Double grouser	650 mm	84 000 kg	121 kPa (1.23 kg/cm ²)

Equipped with 7.1 m BE-boom, 2.95 m BE-arm and 4.3 m³ rock bucket (SAE, PCSA heaped).

Shoe type	Shoe width	Operating weight	Ground pressure
Double grouser	650 mm	84 300 kg	121 kPa (1.23 kg/cm ²)

Equipped with 7.1 m BE-boom, 3.7 m H-arm and 3.7 m³ rock bucket (SAE, PCSA heaped).

Shoe type	Shoe width	Operating weight	Ground pressure
Double grouser	650 mm	83 500 kg	120 kPa (1.23 kg/cm ²)

SERVICE REFILL CAPACITIES

Fuel tank	1 120.0 L
Engine coolant	116.0 L
Engine oil	57.0 L
Pump drive.....	6.2 L
Swing device (each side)	15.0 L
Travel device (each side).....	19.0 L
Hydraulic system.....	790.0 L
Hydraulic oil tank.....	500.0 L

SPECIFICATIONS

ZX870H-3 / ZX870LCH-3

DIMENSIONS

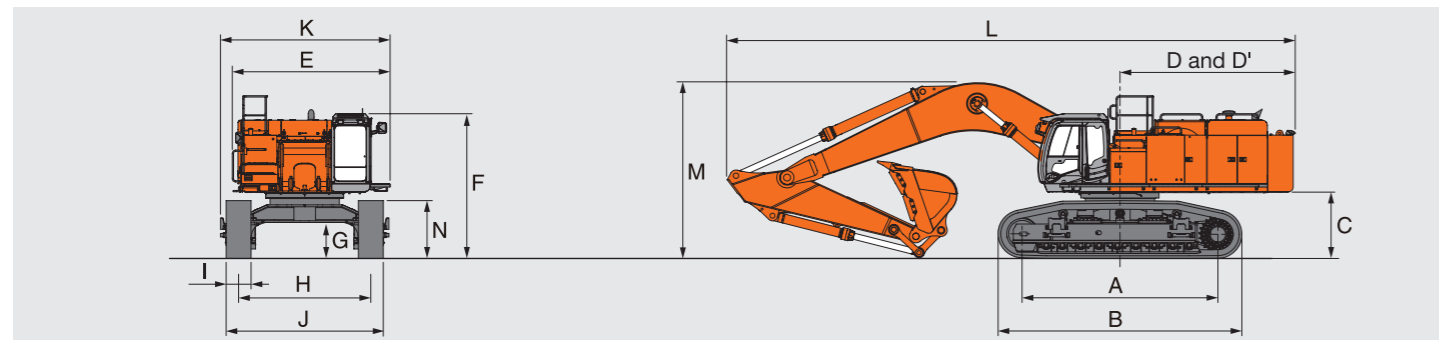

Unit:mm

	ZX870H-3 ¹²	ZX870LCH-3 ²
A Distance between tumblers	4 590	5 110
B Undercarriage length	5 840	6 360
¹ C Counterweight clearance		1 680
D Rear-end swing radius		4 600
D' Rear-end length		4 520
E Overall width of upperstructure		4 120
F Overall height of cab		3 780
¹ G Min. ground clearance		890
H Track gauge		3 450
I Track shoe width		G 650
J Undercarriage width		4 100
K Overall width		4 430
L Overall length		14 770
M Overall height of boom		4 570
N Track height		1 500

¹ Excluding track shoe lug G: Double grouser shoe
² Equipped with 8.4 m H-boom and 3.7 m H-arm

WORKING RANGES

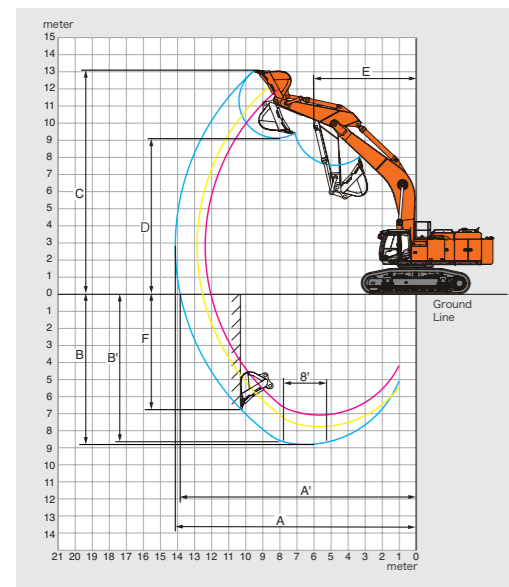

Unit:mm

	ZX870H-3 / ZX870LCH-3		
	7.1 m BE-boom	8.4 m H-boom	3.7 m H-arm
Boom length	7.1 m BE-boom	8.4 m H-boom	3.7 m H-arm
Arm length	2.95 m BE-arm	3.7 m H-arm	3.7 m H-arm
A Max. digging reach	12 340	12 820	14 100
A' Max. digging reach (on ground)	12 020	12 510	13 820
B Max. digging depth	7 140	7 820	8 870
B' Max. digging depth (8' level)	7 000	7 690	8 740
C Max. cutting height	12 010	12 130	13 000
D Max. dumping height	8 130	8 180	9 080
E Min. swing radius	5 210	5 090	5 950
F Max. vertical wall	4 100	6 090	6 840
Bucket digging force* ISO	472 kN (48 200 kgf)	402 kN (41 000 kgf)	402 kN (41 000 kgf)
Bucket digging force* SAE : PCSA	411 kN (41 900 kgf)	359 kN (36 600 kgf)	359 kN (36 600 kgf)
Arm crowd force* ISO	394 kN (40 200 kgf)	324 kN (33 100 kgf)	324 kN (33 100 kgf)
Arm crowd force* SAE : PCSA	378 kN (38 600 kgf)	316 kN (32 200 kgf)	316 kN (32 200 kgf)
Equipped bucket SAE : PCSA	4.3 m ³	3.7 m ³	3.5 m ³

Excluding track shoe lug
* At power boost

LIFTING CAPACITIES

Notes: 1. Ratings are based on SAE J1097.

2. Lifting capacity of the ZAXIS Series does not exceed 75 % of tipping load with the machine on firm, level ground or 87 % full hydraulic capacity.

3. The load point is a hook (not standard equipment) located on the back of the bucket.

4. *Indicates load limited by hydraulic capacity.

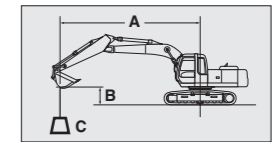

A: Load radius
B: Load point height
C: Lifting capacity

ZX870LCH-3

Rating over-side or 360 degrees

Rating over-front

Unit: 1 000 kg

Conditions	Load point height	Load radius												At max. reach						
		3 m		4 m		6 m		8 m		10 m		12 m		meter	meter	meter				
BE-Boom 7.10 m BE-Arm 2.95 m Rock-Bucket SAE, PCSA: 4.30 m ³ Shoe 650 mm	9.0 m							*12.1	*12.1								*7.4	*7.4	10.2	
	8.0 m							*15.7	*15.7								*7.2	*7.2	10.8	
	6.0 m							*17.2	*17.2								*7.2	*7.2	11.5	
	4.0 m					*26.8	*26.8	19.0	*19.7	12.6	*16.5					*7.5	*7.5	11.8		
	2.0 m							17.8	*22.3	12.0	*17.5					*8.1	*8.1	11.7		
	0 (Ground)							16.9	*23.8	11.5	*17.9					*9.3	*9.3	11.2		
	-2.0 m					26.5	*32.1	16.4	*23.2											
	-4.0 m				*34.6	*34.6	26.8	*27.1	16.6	*19.5										
	-5.0 m							*22.9	*22.9											
H-Boom 8.40 m H-Arm 3.70 m Rock-Bucket SAE, PCSA: 3.70 m ³ Shoe 650 mm	8.0 m																*4.4	*4.4	11.3	
	6.0 m							*15.0	*15.0	*9.4	*9.4					*4.5	*4.5	12.0		
	4.0 m					*24.4	*24.4	*18.7	*18.7	13.2	*14.2					*4.8	*4.8	12.3		
	2.0 m					29.7	*31.0	18.6	*21.7	12.6	*17.3					*5.4	*5.4	12.2		
	0 (Ground)					27.9	*34.4	17.6	*23.9	12.1	*18.2					*6.5	*6.5	11.7		
	-2.0 m	*17.4	*17.4	*26.1	*26.1	27.1	*34.0	17.0	*24.2	11.7	*17.9					*8.3	*8.3	10.7		
	-4.0 m	*37.2	*37.2	*42.5	*42.5	27.1	*30.6	16.9	*22.0											
	-6.0 m					*22.5	*22.5													
H-Boom 8.40 m H-Arm 3.70 m Rock-Bucket SAE, PCSA: 3.50 m ³ Shoe 650 mm	9.0 m									*9.1	*9.1					*5.4	*5.4	12.2		
	8.0 m									*11.6	*11.6					*5.4	*5.4	12.7		
	6.0 m							*14.9	*14.9	*12.9	*12.9					*5.5	*5.5	13.3		
	4.0 m					*26.1	*26.1	*18.0	*18.0	12.5	*14.4	8.7	*10.8	*5.9	*5.9	13.6	*5.9	13.6		
	2.0 m							17.1	*21.0	11.8	*15.9	8.4	*13.2	*6.5	*6.5	13.5	*6.5	13.5		
	0 (Ground)							16.2	*22.8	11.2	*17.1	8.1	13.3	6.9	*7.5	13.1	*7.5	13.1		
	-2.0 m					25.6	*31.8	15.8	*23.1	10.9	*17.3				7.9	*9.1	12.2	*9.1	12.2	
	-4.0 m				*27.4	*27.4	25.9	*29.0	15.9	*21.7	10.9	*16.2				9.9	*11.1	10.8	*11.1	10.8
	-6.0 m					*24.0	*24.0	16.3	*18.1											
	-7.0 m					*20.1	*20.1	*14.5	*14.5											

ZX870H-3

Conditions	Load point height	Load radius												At max. reach						
		3 m		4 m		6 m		8 m		10 m		12 m		meter	meter	meter				
H-Boom 8.40 m H-Arm 3.70 m Rock-Bucket SAE, PCSA: 3.50 m ³ Shoe 650 mm	9.0 m									*9.1	*9.1					*5.4	*5.4	12.2		
	8.0 m									*11.6	*11.6					*5.4	*5.4	12.7		
	6.0 m							*14.9	*14.9	*12.9	*12.9					*5.5	*5.5	13.3		
	4.0 m					*26.1	*26.1	*18.0	*18.0	12.2	*14.4	8.4	*10.8	*5.9	*5.9	13.6	*5.9	13.6		
	2.0 m							16.7	*21.0	11.5	15.7	8.1	11.3	6.4	*6.5	13.5	*6.5	13.5		
	0 (Ground)							15.8	21.8	10.9	15.1	7.8	11.0	6.7	*7.5	13.1	*7.5	13.1		
	-2.0 m					24.9	*31.8	15.4	21.4	10.6	14.8				7.6	*9.1	12.2	*9.1	12.2	
	-4.0 m				*27.4	*27.4	25.2	*29.0	15.4	21.4	10.6	14.8				9.6	*11.1	10.8	*11.1	10.8
	-6.0 m					*24.0	*24.0	15.9	*18.1											
	-7.0 m					*20.1	*20.1	*14.5	*14.5											

EQUIPMENT

ZX870H-3 / ZX870LCH-3

STANDARD EQUIPMENT

Standard equipment may vary by country, so please consult your Hitachi dealer for details.

ENGINE

- H/P mode control
- P mode control
- E mode control
- 50 A alternator
- Dry-type air double filter with evacuator valve (with air filter restriction switch for monitor)
- Cartridge-type engine oil filter
- Cartridge-type fuel filter
- Fuel pre-filter
- Radiator, oil cooler and intercooler with dust protective net
- Radiator reserve tank
- Fan guard
- Isolation-mounted engine
- Auto-idle system

HYDRAULIC SYSTEM

- Work mode selector
- Engine speed sensing system
- E-P control system
- Power boost
- Auto power lift
- Boom mode selector system
- Shockless valve in pilot circuit
- Control valve with main relief valve
- Extra port for control valve
- Suction filter
- Full-flow filter
- Pilot filter
- Drain filter
- Quick warm-up system for pilot circuit

CAB

- H/R cab
- OPG top guard fitted Level II (ISO10262) compliant cab
- All-weather sound suppressed steel cab
- Laminated straight and fixed glass front window
- Left side window can be opened
- 6 fluid-filled elastic mounts
- Intermittent windshield wipers
- Front window washer
- Adjustable reclining suspension seat with adjustable armrests
- Footrest
- Electric double horn
- AM-FM radio with digital clock
- Auto-idle selector
- Retractable Seat belt
- Drink holder
- Cigarette lighter
- Ashtray
- Storage box
- Glove compartment
- Floor mat
- Short wrist control levers
- Auto control air conditioner
- Pilot control shut-off lever
- Engine shut-off switch

MONITOR SYSTEM

- Display of meters: water temperature, hour, fuel rate, clock
- Other displays: work mode, auto-idle, glow, rear view monitor (When optional rear view camera is equipped), operating conditions, etc
- Alarms: overheat, engine warning, engine oil pressure, alternator, minimum fuel level, hydraulic filter restriction, air filter restriction, work mode, etc
- Alarm buzzers: overheat, engine oil pressure

LIGHTS

- 3 working lights
- 2 cab lights

UPPERSTRUCTURE

- 4.5 mm thickness Undercover
- 13 300 kg counterweight
- Fuel level float
- Hydraulic oil level gauge
- Tool box
- Utility space
- Rear view mirror (right & left side)
- Swing parking brake

UNDERCARRIAGE

- Travel parking brake
- Travel motor covers
- Hydraulic track adjuster
- Idler track guard
- Bolt-on sprocket
- Upper and lower rollers
- Reinforced track links with pin seals
- Full track guard
- 650 mm double grouser shoes

FRONT ATTACHMENTS

- Flanged pin
- Centralized lubrication system
- Dirt seal on all bucket pins
- 8.4 m H-boom and 3.7 m H-arm
- Damage prevention plate and square bars
- 3.5 m³ (SAE, PCSA heaped) rock bucket (with dual type side shrouds)

MISCELLANEOUS

- Standard tool kit
- Lockable machine covers
- Lockable fuel filling cap
- Skid-resistant tapes, plates, handrails and sidewalk
- Travel direction mark on track frame
- Onboard information controller
- Theft deterrent system

OPTIONAL EQUIPMENT

Optional equipment may vary by country, so please consult your Hitachi dealer for details.

- Hose rupture valves
- Electric fuel refilling pump with autostop
- Swing motion alarm device with lamps
- Travel motion alarm device
- Biodegradable oil
- Pre cleaner
- Cab front step
- Auto-grease lubricator
- Electric grease gun with hose-reel

- Right side walk
- Rain guard for cab
- Attachment basic piping
- Accessories for breaker
- Accessories for breaker & crusher
- Accessories for 2 speed selector
- Sun visor
- 12 V power source
- Additional fuse box
- Overload alarm
- Rear view camera

- Front glass lower guard
- Front glass upper guard
- Counterweight removal device
- 7.1 m BE-boom
- 2.95 m BE-arm

SPECIFICATIONS

ZX850-3 / ZX850LC-3

ENGINE

Model.....	Isuzu AH-6WG1XYSA-03
Type	4-cycle water-cooled, direct injection
Aspiration.....	Turbocharged
No. of cylinders	6
Rated power	
ISO 9249, net.....	H/P mode :
(Without Fan)	397 kW (532 HP) at 1 800 min ⁻¹ (rpm)
EEC 80/1269, net ...	H/P mode :
(Without Fan)	397 kW (532 HP) at 1 800 min ⁻¹ (rpm)
SAE J1349, net.....	H/P mode :
(Without Fan)	397 kW (532 HP) at 1 800 min ⁻¹ (rpm)
Maximum torque	2 250 Nm (229 kgf m) at 1 600 min ⁻¹ (rpm)
Piston displacement....	15.681 L
Bore and stroke.....	147 mm x 154 mm
Batteries.....	2 x 12 V / 170 Ah

HYDRAULIC SYSTEM

- Work mode selector
 - General purpose mode / Attachment mode
 - Engine speed sensing system
- Main pumps 2 variable displacement axial piston pumps
 Maximum oil flow... 2 x 528 L/min
- Pilot pump..... 1 gear pump
 Maximum oil flow... 30 L/min

Hydraulic Motors

Travel	2 axial piston motors with parking brake
Swing.....	2 axial piston motors

Relief Valve Settings

Implement circuit.....	31.9 MPa (325 kgf/cm ²)
Swing circuit.....	28.4 MPa (290 kgf/cm ²)
Travel circuit	34.3 MPa (350 kgf/cm ²)
Pilot circuit	3.9 MPa (40 kgf/cm ²)
Power boost	34.3 MPa (350 kgf/cm ²)

Hydraulic Cylinders

High-strength hydraulic piston rods and tubes. Cylinder cushion mechanisms provided in boom and arm cylinders to absorb shock at stroke ends.

Dimensions

	Quantity	Bore	Rod diameter
Boom	2	215 mm	150 mm
Arm	1	225 mm	160 mm
Bucket	1	200 mm	140 mm
Bucket (BE)	1	215 mm	150 mm

Hydraulic Filters

Hydraulic circuits use high-quality hydraulic filters. A suction filter is incorporated in the suction line, and full-flow filters in the return line and swing/travel motor drain lines.

CONTROLS

Pilot controls. Hitachi's original shock less valve and quick warm-up system built in the pilot circuit.

Implement levers	2
Travel levers with pedals	2

UPPERSTRUCTURE

Revolving Frame

Welded sturdy box construction, using heavy-gauge steel plates for ruggedness. D-section frame for resistance to deformation.

Swing Device

Axial piston motor with planetary reduction gear is bathed in oil. Swing circle is single-row, shear-type ball bearing with inductionhardened internal gear. Internal gear and pinion gear are immersed in lubricant. Swing parking brake is spring-set/hydraulic-released disc type.
 Swing speed 7.3 min⁻¹ (rpm)

Operator's Cab

Independent spacious cab, 1 005 mm wide by 1 675 mm high, conforming to ISO* Standards. (OPG top guard fitted Level I, ISO 10262 compliant cab) Reinforced glass windows on 4 sides for visibility. Openable front windows (upper and lower). Reclining seat with armrests; adjustable with or without control levers.
 * International Standardization Organization

UNDERCARRIAGE

Tracks

Tractor-type undercarriage. Welded track frame using selected materials. Side frame bolted to track frame. Lubricated track rollers, idlers, and sprockets with floating seals.
 Track shoes with double grousers made of induction-hardened rolled alloy. Heat-treated connecting pins with dirt seals. Hydraulic (grease) track adjusters with shock-absorbing recoil springs.

Numbers of Rollers and Shoes on Each Side

Upper rollers.....	3
Lower rollers.....	8 : ZX850-3 9 : ZX850LC-3
Track shoes.....	47 : ZX850-3 51 : ZX850LC-3
Track guard	2

Travel Device

Each track driven by axial piston motor through reduction gear for counterrotation of the tracks. Sprockets are replaceable. Parking brake is spring-set/hydraulic-released disc type.
 Automatic transmission system: High-Low.

Travel speeds	High : 0 to 4.1 km/h Low : 0 to 3.1 km/h
---------------------	---

Maximum traction force.... 560 kN (57 100 kgf)

Gradeability 70 % (35 degree) continuous

WEIGHTS AND GROUND PRESSURE

ZX850-3 :

Equipped with 8.4 m boom, 3.7 m arm and 3.5 m³ bucket (SAE, PCSA heaped).

Shoe type	Shoe width	Operating weight	Ground pressure
Double grouser	650 mm	80 500 kg	121 kPa (1.23 kg/cm ²)
	750 mm	81 100 kg	105 kPa (1.08 kg/cm ²)

Equipped with 7.1 m BE-boom, 2.95 m BE-arm and 4.5 m³ bucket (SAE, PCSA heaped).

Shoe type	Shoe width	Operating weight	Ground pressure
Double grouser	650 mm	81 200 kg	122 kPa (1.24 kg/cm ²)
	750 mm	81 800 kg	106 kPa (1.09 kg/cm ²)

ZX850LC-3 :

Equipped with 8.4 m boom, 3.7 m arm and 3.5 m³ bucket (SAE, PCSA heaped).

Shoe type	Shoe width	Operating weight	Ground pressure
Double grouser	650 mm	82 200 kg	112 kPa (1.14 kg/cm ²)
	750 mm	82 900 kg	98 kPa (1.00 kg/cm ²)
	900 mm	83 900 kg	82 kPa (0.84 kg/cm ²)

Equipped with 7.1 m BE-boom, 2.95 m BE-arm and 4.5 m³ bucket (SAE, PCSA heaped).

Shoe type	Shoe width	Operating weight	Ground pressure
Double grouser	650 mm	83 000 kg	113 kPa (1.15 kg/cm ²)
	750 mm	83 700 kg	99 kPa (1.01 kg/cm ²)
	900 mm	84 600 kg	83 kPa (0.85 kg/cm ²)

Note: Depending on the jobsites conditions, 750 mm grouser shoe and 900 mm grouser shoe may not be recommended for rock, hard surface or forestry application.

BACKHOE ATTACHMENTS

Boom and arms are of all-welded, box-section design. A number of booms and arms are available. Bucket is of all-welded, high strength steel structure.

Backhoe Buckets

ZX850-3 / ZX850LC-3

Capacity		Width		No. of teeth	Weight	Recommendation		
SAE, PCSA heaped	CECE heaped	Without side cutters	With side cutters			ZX850-3 / ZX850LC-3		
				7.1 m BE-boom	8.4 m boom			
				2.95 m BE-arm	3.7 m arm	4.4 m arm		
2.90 m ³	2.60 m ³	1 590 mm	1 780 mm	5	2 700 kg	X	⊙	⊙
3.50 m ³	3.10 m ³	1 850 mm	2 040 mm	5	2 950 kg	X	⊙	—
4.50 m ³	3.90 m ³	2 120 mm	2 190 mm	5	3 970 kg	⊙	X	X
Applicable shoe type						650 mm Double grouser		
						750 mm Double grouser		
						900 mm Double grouser : ZX850LC-3		

⊙ Suitable for materials with density of 1 800 kg/m³ or less

— Not applicable

X Can't installed

SPECIFICATIONS

ZX850-3 / ZX850LC-3

DIMENSIONS

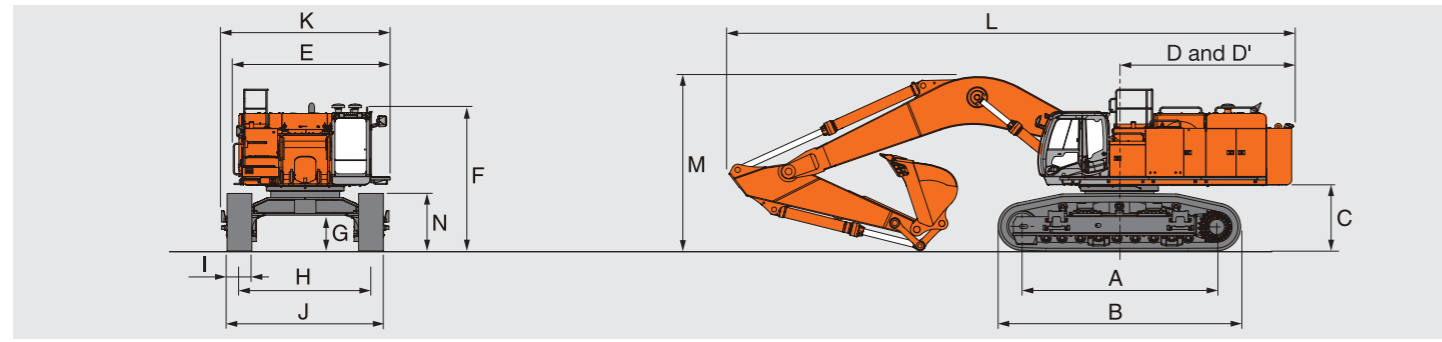

Unit:mm

	ZX850-3 ¹ 2	ZX850LC-3 ¹ 2
A Distance between tumblers	4 590	5 110
B Undercarriage length	5 840	6 360
¹ C Counterweight clearance	1 680	
D Rear-end swing radius	4 600	
D' Rear-end length	4 520	
E Overall width of upperstructure	4 120	
F Overall height of cab	3 630	
¹ G Min. ground clearance	890	
H Track gauge	3 450	
I Track shoe width	G 650	
J Undercarriage width	4 100	
K Overall width	4 430	
L Overall length	14 770	
M Overall height of boom	4 570	
N Track height	1 500	

¹ Excluding track shoe lug G: Double grouser shoe
² Equipped with 8.4 m boom and 3.7 m arm

WORKING RANGES

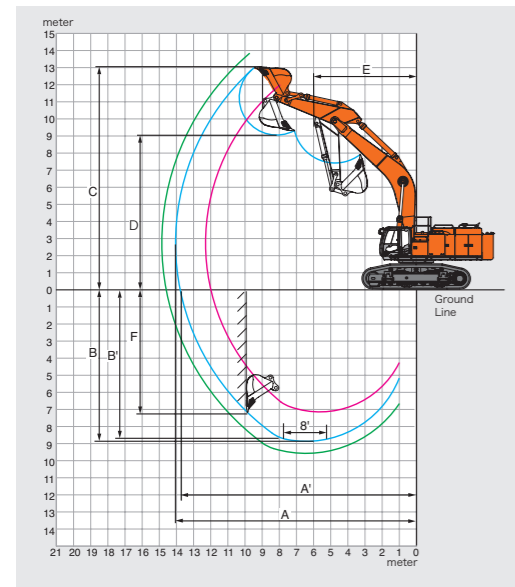

Unit:mm

	ZX850-3 / ZX850LC-3		
Boom length	7.1 m BE-boom	8.4 m boom	
Arm length	2.95 m BE-arm	3.7 m arm	4.4 m arm
A Max. digging reach	12 340	14 100	14 910
A' Max. digging reach (on ground)	12 020	13 820	14 640
B Max. digging depth	7 140	8 870	9 570
B' Max. digging depth (8' level)	7 000	8 740	9 460
C Max. cutting height	12 010	13 030	13 820
D Max. dumping height	8 130	9 080	9 740
E Min. swing radius	5 210	5 950	5 950
F Max. vertical wall	4 100	7 170	8 480
Bucket digging force* ISO	472 kN (48 200 kgf)	399 kN (40 700 kgf)	399 kN (40 700 kgf)
Bucket digging force* SAE : PCSA	411 kN (41 900 kgf)	359 kN (36 600 kgf)	359 kN (36 600 kgf)
Arm crowd force* ISO	394 kN (40 200 kgf)	323 kN (33 000 kgf)	280 kN (28 600 kgf)
Arm crowd force* SAE : PCSA	378 kN (38 600 kgf)	315 kN (32 100 kgf)	273 kN (27 900 kgf)
Equipped bucket SAE : PCSA	4.5 m ³	3.5 m ³	2.9 m ³

Excluding track shoe lug
* At power boost

LIFTING CAPACITIES

- Notes: 1. Ratings are based on SAE J1097.
2. Lifting capacity of the ZAXIS Series does not exceed 75 % of tipping load with the machine on firm, level ground or 87 % full hydraulic capacity.
3. The load point is a hook (not standard equipment) located on the back of the bucket.
4. *Indicates load limited by hydraulic capacity.

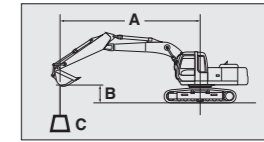

A: Load radius
B: Load point height
C: Lifting capacity

Rating over-side or 360 degrees Rating over-front Unit: 1 000 kg

ZX850LC-3

Conditions	Load point height	Load radius												At max. reach							
		3 m		4 m		6 m		8 m		10 m		12 m				meter					
BE-boom 7.10 m	9.0 m							*12.4	*12.4					*7.7	*7.7	10.2					
BE-arm 2.95 m	8.0 m							*16.0	*16.0					*7.5	*7.5	10.8					
Bucket	6.0 m							*17.4	*17.4					*7.4	*7.4	11.5					
SAE, PCSA: 4.50 m ³	4.0 m							19.1	*19.9	12.7	*16.7			*7.7	*7.7	11.8					
Shoe 650 mm	2.0 m							17.8	*22.6	12.1	*17.7			*8.4	*8.4	11.7					
	0 (Ground)							16.9	*24.1	11.7	*18.2			*9.5	*9.5	11.2					
	-2.0 m					26.6	*32.3	16.5	*23.5	11.5	*15.5										
	-4.0 m			*34.3	*34.3	26.9	*27.2	16.7	*19.8												
	-5.0 m					*22.9	*22.9														
Boom 8.40 m	10.0 m												*8.6	*8.6		*4.5	*4.5	12.7			
Arm 4.40 m	8.0 m												*10.7	*10.7		*4.4	*4.4	13.7			
Bucket	6.0 m												*12.5	*12.5	*9.7	*9.7	*4.4	*4.4	14.3		
SAE, PCSA: 2.90 m ³	4.0 m					*24.7	*24.7	*17.6	*17.6	13.3	*14.3	9.5	*12.2	*4.6	*4.6	14.5					
Shoe 650 mm	2.0 m							17.9	*21.0	12.5	*16.1	9.1	*13.5	*5.0	*5.0	14.4					
	0 (Ground)					*19.6	*19.6	16.8	*23.2	11.9	*17.5	8.7	13.9	*5.6	*5.6	14.0					
	-2.0 m					25.8	*29.2	16.3	*23.9	11.5	*18.1	8.5	13.7	*6.5	*6.5	13.2					
	-4.0 m	*17.9	*17.9	*23.5	*23.5	26.0	*30.9	16.2	*23.0	11.4	*17.5			*8.2	*8.2	12.0					
	-6.0 m			*34.8	*34.8	*26.5	*26.5	16.5	*20.1	11.7	*14.8										
	-7.0 m					*23.2	*23.2	16.9	*17.5												
Boom 8.40 m	9.0 m												*10.0	*10.0		*6.0	*6.0	12.4			
Arm 3.70 m	8.0 m												*12.4	*12.4		*5.9	*5.9	12.8			
Bucket	6.0 m												*15.7	*15.7	*13.6	*13.6		*6.1	*6.1	13.5	
SAE, PCSA: 3.50 m ³	4.0 m												18.9	*19.0	13.0	*15.2	9.3	*12.3	*6.4	*6.4	13.7
Shoe 650 mm	2.0 m												17.5	*22.0	12.3	*16.8	8.9	*13.9	*7.0	*7.0	13.6
	0 (Ground)												16.7	*23.7	11.7	*17.9	8.6	13.8	7.4	*8.0	13.2
	-2.0 m					26.0	*32.2	16.3	*23.8	11.5	*18.1			8.4	*9.5	12.3					
	-4.0 m			*28.7	*28.7	26.3	*29.3	16.4	*22.3	11.5	*16.9			*9.3	*9.3	10.9					
	-6.0 m					*24.0	*24.0	16.8	*18.5												
	-7.0 m					*20.0	*20.0	*14.8	*14.8												

ZX850-3

Conditions	Load point height	Load radius												At max. reach								
		3 m		4 m		6 m		8 m		10 m		12 m				meter						
Boom 8.40 m	9.0 m													*10.0	*10.0		*6.0	*6.0	12.4			
Arm 3.70 m	8.0 m													*12.4	*12.4		*5.9	*5.9	12.8			
Bucket	6.0 m													*15.7	*15.7	13.5	*13.6		*6.1	*6.1	13.5	
SAE, PCSA: 3.50 m ³	4.0 m													18.5	*19.0	12.7	*15.2	9.0	12.2	*6.4	*6.4	13.7
Shoe 650 mm	2.0 m													17.1	*22.0	12.0	16.2	8.7	11.9	6.9	*7.0	13.6
	0 (Ground)													16.3	*22.2	11.4	15.6	8.4	11.5	7.2	*8.0	13.2
	-2.0 m					25.4	*32.2	15.9	21.9	11.2	15.3			8.1	*9.5	12.3						
	-4.0 m			*28.7	*28.7	25.8	*29.3	16.0	21.9	11.2	15.3			*9.3	*9.3	10.9						
	-6.0 m					*24.0	*24.0	16.4	*18.5													
	-7.0 m					*20.0	*20.0	*14.8	*14.8													

EQUIPMENT

ZX850-3 / ZX850LC-3

STANDARD EQUIPMENT

Standard equipment may vary by country, so please consult your Hitachi dealer for details.

ENGINE

- H/P mode control
- P mode control
- E mode control
- 50 A alternator
- Dry-type air double filter with evacuator valve (with air filter restriction switch for monitor)
- Cartridge-type engine oil filter
- Cartridge-type fuel filter
- Fuel pre-filter
- Radiator, oil cooler and intercooler with dust protective net
- Radiator reserve tank
- Fan guard
- Isolation-mounted engine
- Auto-idle system

HYDRAULIC SYSTEM

- Work mode selector
- Engine speed sensing system
- E-P control system
- Power boost
- Auto power lift
- Boom mode selector system
- Shockless valve in pilot circuit
- Control valve with main relief valve
- Extra port for control valve
- Suction filter
- Full-flow filter
- Pilot filter
- Drain filter
- Quick warm-up system for pilot circuit

CAB

- CRES II cab
- OPG top guard fitted Level I (ISO10262) compliant cab
- All-weather sound suppressed steel cab
- Tinted (green color) glass windows
- 6 fluid-filled elastic mounts
- Openable windows ; upper and lower front, and left side
- Intermittent windshield wipers
- Front window washer
- Adjustable reclining suspension seat with adjustable armrests
- Footrest
- Electric double horn
- AM-FM radio with digital clock
- Auto-idle selector
- Retractable Seat belt
- Drink holder
- Cigarette lighter
- Ashtray
- Storage box
- Glove compartment
- Floor mat
- Short wrist control levers
- Pilot control shut-off lever
- Auto control air conditioner
- Pilot control shut-off lever
- Engine shut-off switch

MONITOR SYSTEM

- Display of meters: water temperature, hour, fuel rate, clock
- Other displays: work mode, auto-idle, glow, rear view monitor (When optional rear view camera is equipped), operating conditions, etc
- Alarms: overheat, engine warning, engine oil pressure, alternator, minimum fuel level, hydraulic filter restriction, air filter restriction, work mode, etc
- Alarm buzzers: overheat, engine oil pressure

LIGHTS

- 3 working lights
- 2 cab lights

UPPERSTRUCTURE

- Undercover
- 13 300 kg counterweight
- Fuel level float
- Hydraulic oil level gauge
- Tool box
- Utility space
- Rear view mirror (right & left side)
- Swing parking brake

UNDERCARRIAGE

- Travel parking brake
- Travel motor covers
- 2 track guard and hydraulic track adjuster
- Idler track guard
- Bolt-on sprocket
- Upper and lower rollers
- Reinforced track links with pin seals
- 650 mm double grouser shoes

FRONT ATTACHMENTS

- Flanged pin
- Centralized lubrication system
- Dirt seal on all bucket pins
- 8.4 m boom and 3.7 m arm
- 3.5 m³ (SAE, PCSA heaped) bucket

MISCELLANEOUS

- Standard tool kit
- Lockable machine covers
- Lockable fuel filling cap
- Skid-resistant tapes, plates, handrails and sidewalk
- Travel direction mark on track frame
- Onboard information controller
- Theft deterrent system

OPTIONAL EQUIPMENT

Optional equipment may vary by country, so please consult your Hitachi dealer for details.

- H/R cab : OPG top guard fitted Level II (ISO10262) compliant cab (with 2 cab lights)
- Hose rupture valves
- Electric fuel refilling pump with autostop
- Swing motion alarm device with lamps
- Travel motion alarm device
- Biodegradable oil
- Pre cleaner

- Cab front step
- Auto-grease lubricator
- Electric grease gun with hose-reel
- Right side walk
- Rain guard for cab
- Attachment basic piping
- Accessories for 2 speed selector
- 12 V power source
- Additional fuse box
- Overload alarm
- Rear view camera

- Front glass lower guard
- Front glass upper guard
- Full track guard
- 750 mm double grouser shoe
- 900 mm double grouser shoe : ZX850LC-3
- Counterweight removal device
- 7.1 m BE-boom
- 2.95 m BE-arm
- 4.4 m arm

TRANSPORTATION

TRANSPORTATION

UPPERSTRUCTURE

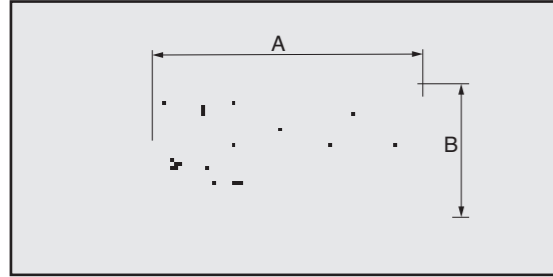

	A	B	Overall width	Weight
ZX850-3	6 040 mm	2 960 mm	3 500 mm	27 300 kg
ZX850LC-3				
ZX870H-3	6 040 mm	2 960 mm	3 500 mm	27 500 kg
ZX870LCH-3				

SIDE FRAME

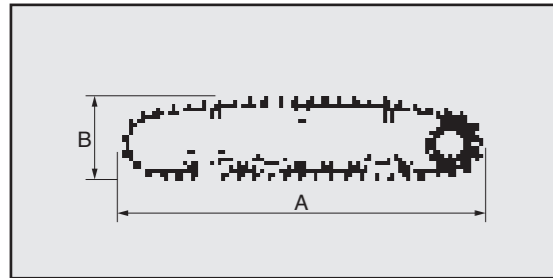

	Shoe width	A	B	Overall width	Weight
ZX850-3	650 mm	5 840 mm	1 500 mm	1 330 mm	11 200 kg
	750 mm	5 840 mm	1 500 mm	1 330 mm	11 500 kg
ZX850LC-3	650 mm	6 360 mm	1 500 mm	1 330 mm	12 100 kg
	750 mm	6 360 mm	1 500 mm	1 330 mm	12 400 kg
ZX870H-3	650 mm	5 840 mm	1 500 mm	1 330 mm	11 400 kg
ZX870LCH-3	650 mm	6 360 mm	1 500 mm	1 330 mm	12 400 kg

COUNTERWEIGHT

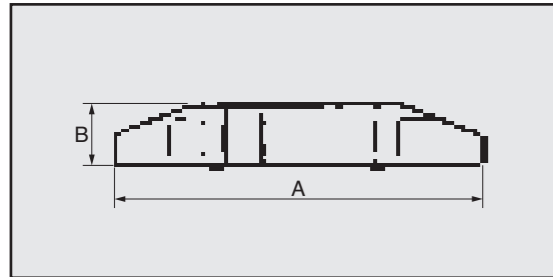

A	B	Overall height	Weight
3 360 mm	720 mm	1 620 mm	13 300 kg

BASIC MACHINE (WITHOUT COUNTERWEIGHT)

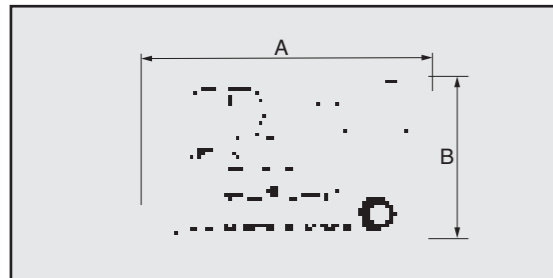

	Shoe width	A	B	Overall width	Weight
ZX850-3	650 mm	6 770 mm	3 670 mm	3 600 mm	49 800 kg
	750 mm	6 770 mm	3 670 mm	3 700 mm	50 500 kg
ZX850LC-3	650 mm	7 080 mm	3 670 mm	3 600 mm	51 600 kg
	750 mm	7 080 mm	3 670 mm	3 700 mm	52 300 kg
ZX870H-3	650 mm	6 770 mm	3 790 mm	3 600 mm	50 500 kg
ZX870LCH-3	650 mm	7 080 mm	3 790 mm	3 600 mm	52 430 kg

TRANSPORTATION

BOOM

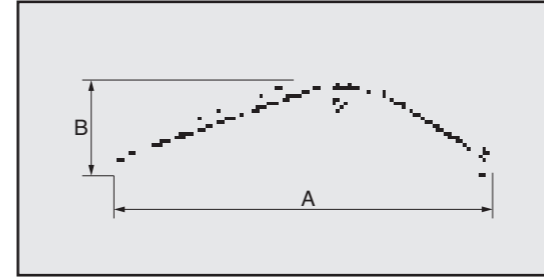

Boom	A	B	Overall width	Weight
7.1 m BE	7 490 mm	2 700 mm	1 450 mm	7 670 kg
8.4 m H	8 780 mm	2 500 mm	1 450 mm	8 200 kg
8.4 m	8 780 mm	2 500 mm	1 450 mm	8 200 kg

ARM



Arm	A	B	Overall width	Weight
2.95 m BE	4 460 mm	1 660 mm	850 mm	4 650 kg
3.7 m H	5 290 mm	1 420 mm	820 mm	4 510 kg
3.7 m	5 290 mm	1 420 mm	820 mm	4 330 kg
4.4 m	5 880 mm	1 420 mm	820 mm	4 660 kg

BUCKET

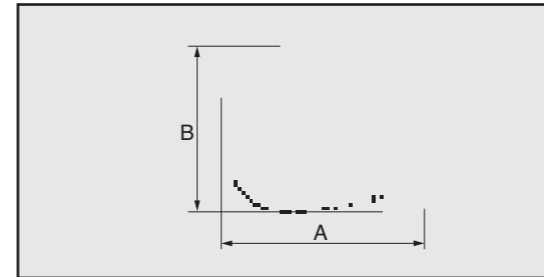

Capacity		A	B	Overall width	Weight
SAE, PCSA heaped	CECE heaped				
2.90 m³	2.60 m³	2 210 mm	1 910 mm	1 780 mm	2 700 kg
3.50 m³	3.10 m³	2 210 mm	1 910 mm	2 040 mm	2 950 kg
4.50 m³	3.90 m³	2 320 mm	2 000 mm	2 190 mm	3 970 kg
*13.50 m³	3.10 m³	2 240 mm	1 920 mm	1 890 mm	3 790 kg
*13.70 m³	3.20 m³	2 240 mm	1 920 mm	1 970 mm	3 900 kg
*14.30 m³	3.80 m³	2 320 mm	2 000 mm	2 110 mm	4 270 kg

*1 Rock bucket

BOOM CYLINDERS 850 kg x 2

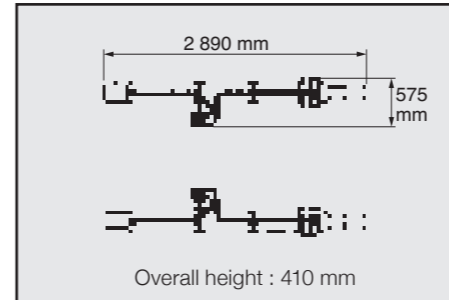

HOSE OF BOOM CYLINDERS 13 kg x 2 / 9 kg x 2

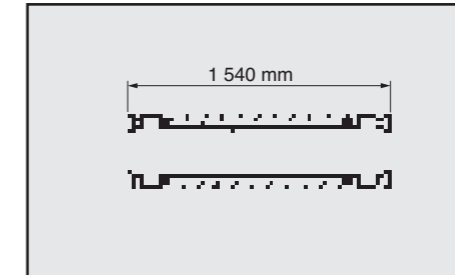

LEFT SIDEWALK

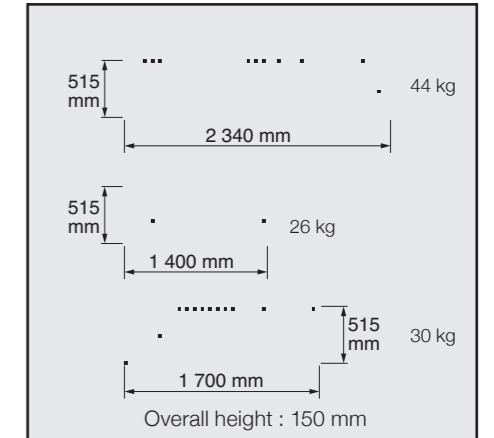

SPECIFICATIONS

ZX850-3 / ZX870H-3 LOADING SHOVEL

ENGINE

Model.....	Isuzu AH-6WG1XYSA-03
Type	4-cycle water-cooled, direct injection
Aspiration.....	Turbocharged
No. of cylinders	6
Rated power	
ISO 9249, net.....	H/P mode :
(Without Fan)	397 kW (532 HP) at 1 800 min ⁻¹ (rpm)
EEC 80/1269, net ...	H/P mode :
(Without Fan)	397 kW (532 HP) at 1 800 min ⁻¹ (rpm)
SAE J1349, net.....	H/P mode :
(Without Fan)	397 kW (532 HP) at 1 800 min ⁻¹ (rpm)
Maximum torque	2 250 Nm (229 kgf m) at 1 600 min ⁻¹ (rpm)
Piston displacement....	15.681 L
Bore and stroke.....	147 mm x 154 mm
Batteries.....	2 x 12 V / 170 Ah

HYDRAULIC SYSTEM

- Engine speed sensing system
- | | |
|---------------------|--|
| Main pumps | 2 variable displacement axial piston pumps |
| Maximum oil flow... | 2 x 528 L/min |
| Pilot pump..... | 1 gear pump |
| Maximum oil flow... | 30 L/min |

Hydraulic Motors

Travel	2 axial piston motors with parking brake
Swing.....	2 axial piston motors

Relief Valve Settings

Implement circuit	29.4 MPa (300 kgf/cm ²)
Swing circuit.....	28.4 MPa (290 kgf/cm ²)
Travel circuit	34.3 MPa (350 kgf/cm ²)
Pilot circuit	3.9 MPa (40 kgf/cm ²)

Hydraulic Cylinders

High-strength piston rods and tubes. Cylinder cushion mechanisms provided in boom and arm cylinders to absorb shock at stroke ends.

Dimensions

	Quantity	Bore	Rod diameter
Boom	2	200 mm	140 mm
Arm	1	200 mm	140 mm
Bucket	2	180 mm	130 mm
Dnmp	2	130 mm	80 mm
Level	1	200 mm	140 mm

Hydraulic Filters

Hydraulic circuits use high-quality hydraulic filters. A suction filter is incorporated in the suction line, and full-flow filters in the return line and swing/travel motor drain lines.

CONTROLS

Pilot controls. Hitachi's original shock less valve and quick warm-up system built in the pilot circuit.

Implement levers	2
Travel levers with pedals	2

UPPERSTRUCTURE

Revolving Frame

Welded sturdy box construction, using heavy-gauge steel plates for ruggedness. D-section frame for resistance to deformation.

Swing Device

Axial piston motor with planetary reduction gear is bathed in oil. Swing circle is single-row, shear-type ball bearing with inductionhardened internal gear. Internal gear and pinion gear are immersed in lubricant. Swing parking brake is spring-set/hydraulic-released disc type.
Swing speed 7.3 min⁻¹ (rpm)

Operator's Cab

Independent spacious cab, 1 005 mm wide by 1 795 mm high, conforming to ISO* Standards. (OPG top guard fitted Level II, ISO 10262 compliant cab) Reinforced glass windows on 4 sides for visibility. Reclining seat with armrests; adjustable with or without control levers.
* International Standardization Organization

UNDERCARRIAGE

Tracks

Tractor-type undercarriage. Welded track frame using selected materials. Side frame bolted to track frame. Lubricated track rollers, idlers, and sprockets with floating seals. Track shoes with triple grousers made of induction-hardened rolled alloy. Heat-treated connecting pins with dirt seals. Hydraulic (grease) track adjusters with shock-absorbing recoil springs.

Numbers of Rollers and Shoes on Each Side

Upper rollers.....	3
Lower rollers.....	8
Track shoes.....	47
Track guard.....	2 (ZX850-3)
Full length track guard	1 (ZX870H-3)

Travel Device

Each track driven by axial piston motor through reduction gear for counterrotation of the tracks. Sprockets are replaceable. Parking brake is spring-set/hydraulic-released disc type. Automatic transmission system: High-Low.

Travel speeds	High : 0 to 4.1 km/h
	Low : 0 to 3.1 km/h

Maximum traction force....	560 kN (57 100 kgf)
----------------------------	---------------------

Gradeability	70 % (35 degree) continuous
--------------------	-----------------------------

WEIGHTS AND GROUND PRESSURE

ZX850-3:

Equipped with 4.0 m³ bottom dump bucket (PCSA heaped).

Shoe type	Shoe width	Operating weight	Ground pressure
Double grouser	650 mm	81 700 kg	123 kPa (1.25 kgf/cm ²)

Equipped with 4.4 m³ tilt dump bucket (PCSA heaped).

Shoe type	Shoe width	Operating weight	Ground pressure
Double grouser	650 mm	80 700 kg	121 kPa (1.23 kgf/cm ²)

ZX870H-3:

Equipped with 3.6 m³ bottom dump bucket (PCSA heaped).

Shoe type	Shoe width	Operating weight	Ground pressure
Double grouser	650 mm	82 800 kg	132 kPa (1.34 kgf/cm ²)

Equipped with 4.0 m³ tilt dump bucket (PCSA heaped).

Shoe type	Shoe width	Operating weight	Ground pressure
Double grouser	650 mm	81 700 kg	130 kPa (1.23 kgf/cm ²)

LOADING SHOVEL ATTACHMENTS

Boom and arm are of all-welded, box-section design. Efficient, automatic level crowding achieved by one-lever control because the parallel link mechanism keeps the bucket digging angle constant, and level cylinder circuit maintains the bucket height constant. (Auto-Leveling Crowd Mechanism)

Loading Shovel Bucket (PCSA heaped) ZX850-3 / ZX870H-3

Type	Capacity	Width	No. of teeth	Weight	Remarks
Bottom dump	3.60 m ³	2 300 mm	6	6 080 kg	Rock bucket
	4.00 m ³	2 460 mm	6	5 620 kg	General purpose bucket
Tilt dump	4.00 m ³	2 360 mm	6	4 980 kg	Rock bucket
	4.40 m ³	2 520 mm	6	4 630 kg	General purpose bucket

SERVICE REFILL CAPACITIES

Fuel tank	1 120.0 L
Engine coolant	116.0 L
Engine oil	57.0 L
Pump drive.....	6.2 L
Swing device (each side)	15.0 L
Travel device (each side).....	19.0 L
Hydraulic system.....	790.0 L
Hydraulic oil tank.....	500.0 L

SPECIFICATIONS

ZX850-3 / ZX870H-3 LOADING SHOVEL

DIMENSIONS

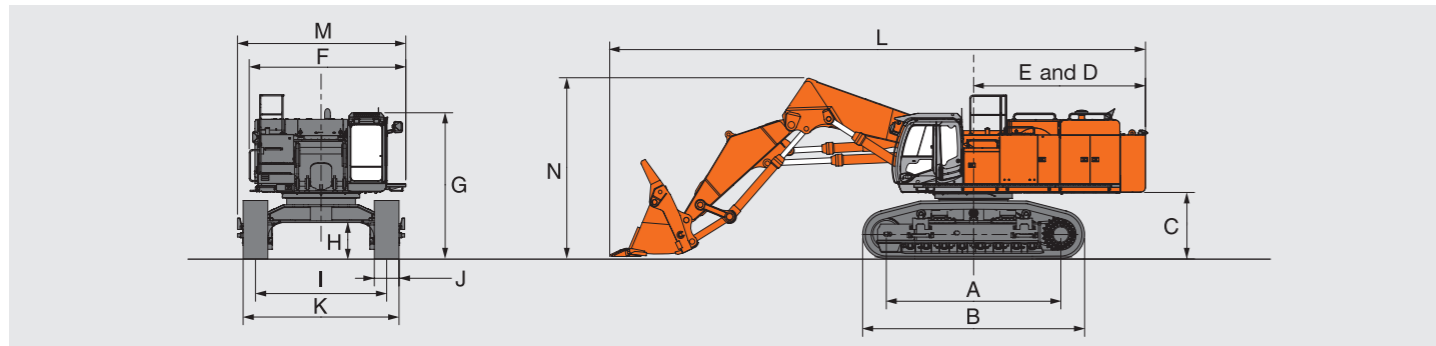

Unit:mm

	ZX850-3	ZX870H-3
A Distance between tumbler	4 590	
B Undercarriage length	5 840	
* C Counterweight clearance	1 680	
D Rear-end swing radius	4 600	
E Rear-end length	4 520	
F Overall width of upperstructure	4 120	
G Overall height of cab	3 630	3 780
* H Min. ground clearance	890	
I Track gauge	3 450	
J Track shoe width	650	
K Undercarriage width	4 100	
L Overall length	14 110	
M Overall width	4 430	
N Overall height of boom	4 900	

* Excluding track shoe lug

WORKING RANGES

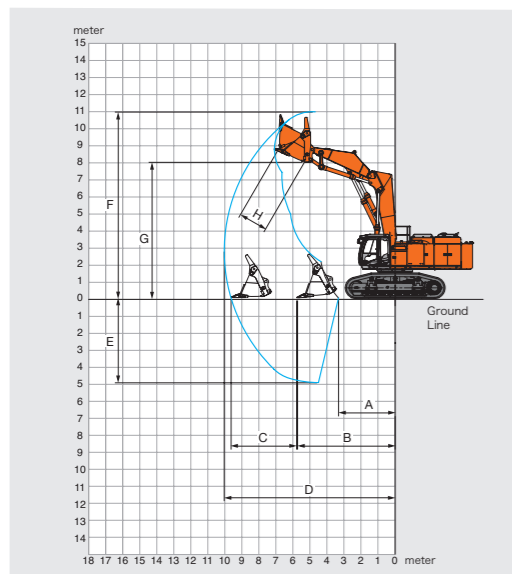

Unit:mm

	ZX850-3	ZX870H-3
	Bottom dump type	Tilt dump type
A Min. digging distance	3 310	3 110
B Min. Level crowding distance		5 730
C Level crowding distance		3 860
D Max. digging reach		10 000
E Max. digging depth		4 970
F Max. cutting height		10 860
G Max. dumping height	7 910	4 970
H Max. bucket opening width	1 600	-
Digging force kN (kgf)	441 (45 000)	

TRANSPORTATION

TRANSPORTATION

BASIC MACHINE (WITHOUT COUNTERWEIGHT)



	Shoe width	A	B	Overall width	Weight
ZX850-3	650 mm	6 770 mm	3 670 mm	3 600 mm	49 700 kg
ZX870H-3	650 mm	6 770 mm	3 790 mm	3 600 mm	50 400 kg

COUNTERWEIGHT 13 200 kg

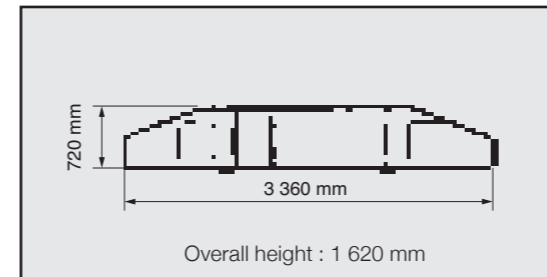

LOADING SHOVEL FRONT ATTACHMENT

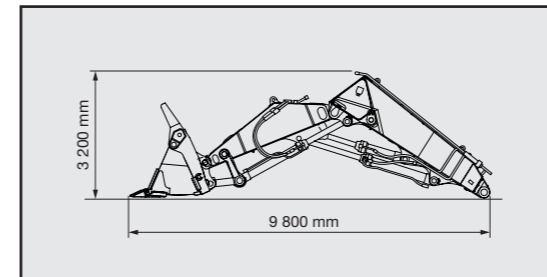

Bucket capacity (PCSA heaped)	Weight	Overall width
3.60 m ³	17 500 kg	2 400 mm
4.00 m ³	17 000 kg	2 560 mm

LOADING SHOVEL FRONT ATTACHMENT (WITHOUT BUCKET)

Weight : 11 450 kg

Overall width : 1 450 mm

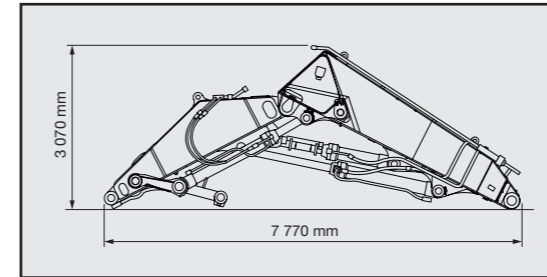

LOADING SHOVEL BUCKET

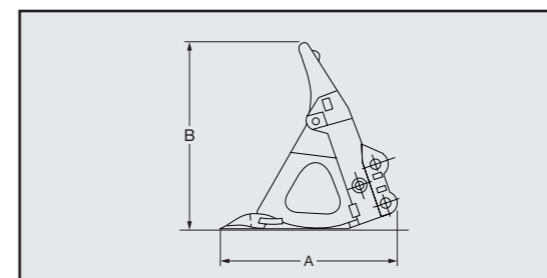

Bucket capacity	A	B	Max.width	Weight	Type
3.60 m ³	2 280 mm	2 570 mm	2 300 mm	6 080 mm	Bottom dump type rock bucket
4.00 m ³	2 300 mm	2 570 mm	2 460 mm	5 620 mm	Bottom dump type general purpose bucket
4.00 m ³	2 290 mm	2 560 mm	2 360 mm	4 980 mm	Tilt dump type rock bucket
4.30 m ³	2 290 mm	2 560 mm	2 560 mm	4 630 mm	Tilt dump type general purpose bucket

Notes : Refer to data on the P30,31 mention for upperstructure, sideframe, boom cylinder, side walk, etc.

ZX850-3 / ZX870H-3 LOADING SHOVEL

STANDARD EQUIPMENT

Standard equipment may vary by country, so please consult your Hitachi dealer for details.

ENGINE	CAB	MONITOR SYSTEM	UNDERCARRIAGE
<ul style="list-style-type: none"> - H/P mode control - P mode control - E mode control - 50 A alternator - Dry-type air double filter with evacuator valve (with air filter restriction switch for monitor) - Cartridge-type engine oil filter - Cartridge-type fuel filter - Fuel pre-filter - Radiator, oil cooler and intercooler with dust protective net - Radiator reserve tank - Fan guard - Isolation-mounted engine - Auto-idle system 	<ul style="list-style-type: none"> - CRES II cab (ZX850-3) - OPG top guard fitted Level I (ISO10262) compliant cab (ZX850-3) - H/R cab (ZX870H-3) - OPG top guard fitted Level II (ISO10262) compliant cab (ZX870H-3) - All-weather sound suppressed steel cab - Laminated round glass (green color) window - 6 fluid-filled elastic mounts - Openable windows ; upper and lower front, and left side - Intermittent windshield wipers - Front window washer - Adjustable reclining suspension seat with adjustable armrests - Electric double horn - AM-FM radio with digital clock - Auto-idle selector - Retractable Seat belt - Drink holder - Cigarette lighter - Ashtray - Storage box - Glove compartment - Floor mat - Short wrist control levers - Auto control air conditioner - Plot control shut-off lever - Engine shut-off switch 	<ul style="list-style-type: none"> - Display of meters: water temperature, hour, fuel rate, clock - Other displays ; auto-idle, glow, rear view monitor (When optional rear view camera is equipped), operating conditions, etc - Alarms ; overheat, engine warning, engine oil pressure, alternator, minimum fuel level, hydraulic filter restriction, air filter restriction etc - Alarms buzzers ; overheat, engine oil pressure 	<ul style="list-style-type: none"> - Travel parking brake - Travel motor covers - Hydraulic track adjuster - Idler track guard - Bolt-on sprocket - Track guard (ZX850-3) - Full track guard (ZX870H-3) - Upper and lower rollers - Reinforced track links with pin seals - 650 mm double grouser shoes
<h4>HYDRAULIC SYSTEM</h4> <ul style="list-style-type: none"> - Engine speed sensing system - E-P control system - Shockless valve in pilot circuit - Control valve with main relief valve - Suction filter - Full-flow filter - Pilot filter - Drain filter - Quick warm-up system for pilot circuit 		<h4>LIGHTS</h4> <ul style="list-style-type: none"> - 3 working lights - 2 cab lights 	<h4>FRONT ATTACHMENTS</h4> <ul style="list-style-type: none"> - Loading shovel front with Auto-Leveling Crowd mechanism - Dual-support-type boom / arm / bucket pin linkage - Double lip seals plus O-ring with protector ring at arm top - 4.0 m³ (PCSA heaped) Bottom dump type general purpose bucket (ZX850-3) - 3.6 m³ (PCSA heaped) Bottom dump type rock bucket (ZX870H-3)
		<h4>UPPERSTRUCTURE</h4> <ul style="list-style-type: none"> - Undercover (ZX850-3) - 4.5 mm thickness Undercover (ZX870H-3) - 13 300 kg counterweight - Fuel level float - Hydraulic oil level gauge - Tool box - Utility space - Rear view mirror (right & left side) - Swing parking brake 	

OPTIONAL EQUIPMENT

Optional equipment may vary by country, so please consult your Hitachi dealer for details.

<ul style="list-style-type: none"> - Swing motion alarm devise with lamps - Travel motion alarm device - Biodegradable oil - Pre cleaner - Additional 2 cab lights - Rain guard top cab - 12 V power source - Additional fuse box - Sun visor - Full track guard (ZX850-3) 	<ul style="list-style-type: none"> - Suspension seat with heater - Air suspension seat with heater - Truck under cover - 4.4 m³ (PCSA heaped) Bottom dump type general purpose bucket (ZX850-3) - 4.0 m³ (PCSA heaped) Bottom dump type rock bucket (ZX870H-3)
--	---

These specifications are subject to change without notice.

Illustrations and photos show the standard models, and may or may not include optional equipment, accessories, and all standard equipment with some differences in color and features.

Before use, read and understand the Operator's Manual for proper operation.

