

HITACHI

Mini-Excavator **Zaxis35U** Specifications

Rated Engine Power

DIN 6271, net 22.5 kW (30.6 PS)

SAE J1349, net 23.0 kW (30.9 hp)

Operating Weight

(Rubber shoes) (Grouser shoes)

2-Pillar canopy version 3 480 kg 3 550 kg

4-Pillar canopy version 3 540 kg 3 610 kg

Cab version 3 600 kg 3 670 kg

Backhoe Buckets

ISO 7451 0.055 – 0.15 m³

The 2- or 4-pillar canopy, or cab can be mounted on the upper-structure according to job needs and applicable regulations. The 4-pillar canopy and cab conform to TOPS (ISO 12117) and FOPS (ISO 10262, Level I) requirements.*

** Cab requires optional top guard.*

■ DIMENSIONS

Unit : mm

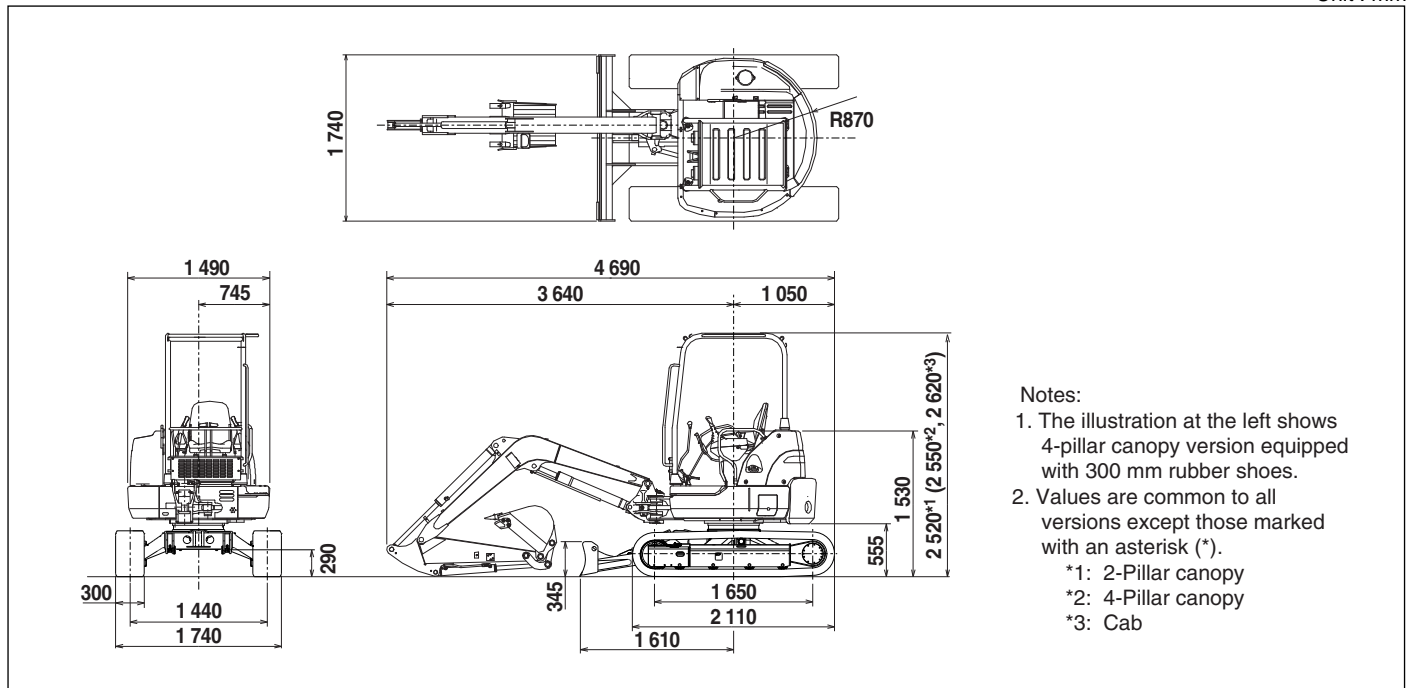

■ WORKING RANGES

Unit : mm

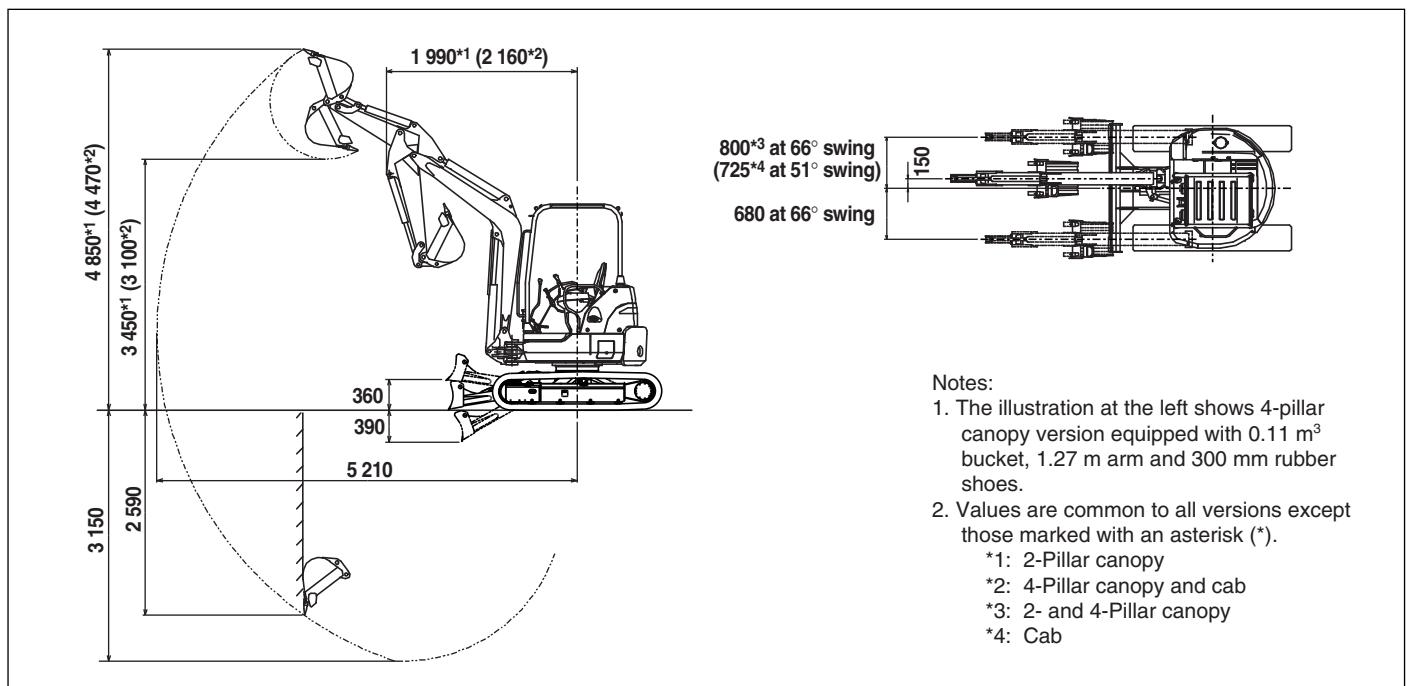

ENGINE

Model..... Isuzu AA-3LD2
 Type..... Water-cooled, 4-cycle, 3-cylinder direct injection type diesel engine
 Rated power..... 22.5 kW (30.6 PS)
 DIN 6271, net at 2 450 min⁻¹ (rpm)
 Rated power..... 23.0 kW (30.9 hp)
 SAE J1349, net at 2 450 min⁻¹ (rpm)
 Maximum torque..... 97 N·m (9.9 kgf·m)
 at 1 800 min⁻¹ (rpm)
 Piston displacement..... 1.496 L
 Bore and stroke..... 83.1 mm x 92 mm
 Battery..... 1 x 12 V, 52 Ah

HYDRAULIC SYSTEM

The Optimum Hydraulic System (OHS) uses three pumps for job efficiency and smooth combined operations.

Main pumps..... Two variable displacement axial piston pumps
 Maximum oil flow..... 2 x 40.8 L/min
 Third pump..... One gear pump
 Maximum oil flow..... 26.8 L/min
 Pilot pump..... One gear pump
 Maximum oil flow..... 9.9 L/min

Relief Valve Settings

Implement circuit..... 24.5 MPa (250 kgf/cm²)
 Swing circuit..... 16.2 MPa (165 kgf/cm²)
 Travel circuit..... 24.5 MPa (250 kgf/cm²)
 Pilot circuit..... 3.9 MPa (40 kgf/cm²)

Hydraulic Cylinders

High-strength piston rods and tubes. Cylinder cushion mechanisms provided in boom raise, arm roll-in and roll-out circuits to absorb shocks at stroke ends.

Dimensions

	No.	Bore	Rod dia.	Stroke
Boom.....	1	80 mm	50 mm	566 mm (540 mm)
Arm.....	1	75 mm	40 mm	563 mm
Bucket.....	1	65 mm	40 mm	445 mm
Boom swing...	1	85 mm	45 mm	517 mm
Blade.....	1	95 mm	45 mm	140 mm

Note: The figure in () shows the stroke for 4-pillar canopy version and cab version.

CONTROLS

Hydraulic pilot control levers for all operations.

SWING MECHANISM

High-torque, axial piston motor with planetary reduction gear. Swing circle is single-row, shear-type ball bearing with induction-hardened internal gear. Internal gear and pinion are immersed in lubricant. Swing parking brake is spring-set/hydraulic-released disc type. Swing shockless valve built in swing motor absorbs shocks when stopping swing, ensuring smooth stops.

Swing speed..... 9.0 min⁻¹ (9.0 rpm)

UNDERCARRIAGE

Tracks

Tractor-type undercarriage. Welded track frame using carefully selected materials. Side frame welded to track frame.

Numbers of Rollers on Each Side

Upper roller..... 1
 Lower rollers..... 4

Traction Device

Each track driven by a high-torque, 2-speed axial piston motor through planetary reduction gear, allowing counter-rotation of the tracks. Travel shockless relief valve built in travel motor absorbs shocks when stopping travel, ensuring smooth stops. Parking brake is spring-set / hydraulic-released disc type.

Travel speeds (rubber shoes)..... High : 0 – 4.4 km/h
 Low : 0 – 2.8 km/h

Travel speeds (grouser shoes)..... High : 0 – 4.3 km/h
 Low : 0 – 2.7 km/h

Gradeability..... 30 degrees (58%) continuous

WEIGHTS AND GROUND PRESSURE

Equipped with 2.45 m boom, 1.27 m arm and 0.11 m³ (PCSA heaped) bucket

	Operating weight	Ground pressure
2-Pillar canopy version		
300 mm rubber shoes....	3 480 kg	31 kPa (0.32 kgf/cm ²)
300 mm grouser shoes..	3 550 kg	32 kPa (0.33 kgf/cm ²)
4-Pillar cab version		
300 mm rubber shoes....	3 540 kg	32 kPa (0.33 kgf/cm ²)
300 mm grouser shoes..	3 610 kg	33 kPa (0.33 kgf/cm ²)
Cab version		
300 mm rubber shoes....	3 600 kg	33 kPa (0.33 kgf/cm ²)
300 mm grouser shoes..	3 670 kg	33 kPa (0.34 kgf/cm ²)

FRONT-END ATTACHMENTS

Backhoe Buckets

ISO 7451 capacity	Width		No. of teeth	Weight	Use	
	Without side cutters	With side cutters			1.27 m Std. arm	1.67 m Long arm
0.055 m ³	300 mm	350 mm	3	61 kg	A	A
0.065 m ³	350 mm	400 mm	3	64 kg	A	A
0.08 m ³	400 mm	450 mm	3	67 kg	A	A
0.09 m ³	450 mm	500 mm	4	71 kg	A	A
0.10 m ³	500 mm	550 mm	4	74 kg	A	A
0.11 m ³	550 mm	600 mm	4	78 kg	A	B
0.13 m ³	600 mm	650 mm	4	82 kg	B	C
0.14 m ³	650 mm	700 mm	4	85 kg	C	D
0.15 m ³	700 mm	750 mm	4	88 kg	C	D

Arm crowd force	19.1 kN (1 950 kgf)	16.7 kN (1 700 kgf)
Bucket digging force	27.4 kN (2 800 kgf)	

A: General digging C: Loading
 B: Light-duty digging D: Not recommended

Boom swing angle

2- and 4-pillar canopy versions..... Left 66°, Right 66°
 Cab version..... Left 66°, Right 51°

STANDARD EQUIPMENT

Engine

• Water-separator for engine fuel system

Hydraulic System

- Hydraulic pilot type control levers
- Pilot control shut-off levers
- Anti-drift valve for front attachments
- Two-speed travel system
- Swing parking brake

Operator's Room

- Two work lights
- Heater*²
- Windshield wiper*²
- Evacuation hammer*²
- Seat belt*¹

Notes: *¹ : For 4-pillar canopy and cab versions
 *² : For cab versions

Undercarriage

- 300 mm rubber shoes
- Semi-long stay blade

Front Attachments

- 2.45 m boom
- 1.27 m arm
- 0.11 m³ hoe bucket
- Bucket clearance adjusting device
- O-ring type pin-seals for hoe bucket
- HN bushing

OPTIONAL EQUIPMENT

Engine

- Auto-idling system

Hydraulic System

- Hydraulic P.T.O. port
- Hydraulic piping for breaker
- Travel parking brake
- Swing motion alarm device with lamp
- Travel motion alarm device

Operator's Room

- Heater*²
- Air cooler*³
- Seat belt*¹
- Windshield washer*³
- Wrist rest
- 12V outlet
- Air cleaner inner element
- FOPS top guard*³
- 2-way control lever pattern selector valve (Excavator/Backhoe loader)

Notes: *¹ : For 2-pillar canopy version
 *² : For 2- and 4-pillar canopy versions
 *³ : For cab version

Undercarriage

- 300 mm grouser shoes
- 400 mm triangle shoes
- 400 mm grouser shoes
- 300 mm pad crawler shoes

Front Attachments

- 1.67 m arm
- Backhoe buckets; see page 2.

Counterweight

- Weight-added counterweight (260 kg added)

LIFTING CAPACITIES (Equipped with 2-pillar canopy)

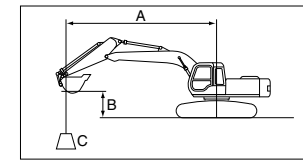

A: Load radius
 B: Load point height
 C: Lifting capacity

With dozer blade above ground

Rating over-side or 360 degrees Rating over-front Unit: t

Conditions	Load Point Height	Load Radius				Maximum Reach			
		2 m	3 m	4 m	meter	meter	meter		
Arm: 1.27 m Bucket: 0.11 m ³ ISO 7451 Rubber shoes: 300 mm	3 m					0.40	*0.40	4.55	
	2 m		*0.71	*0.71	0.48	0.50	0.34	0.34	4.93
	1 m		0.72	0.75	0.46	0.48	0.32	0.33	5.01
	Ground		0.69	0.71	0.45	0.46	0.34	0.35	4.81
	- 1 m	1.33	1.42	0.68	0.71	0.44	0.45	0.41	0.42

With dozer blade on ground

Unit: t

Conditions	Load Point Height	Load Radius				Maximum Reach			
		2 m	3 m	4 m	meter	meter	meter		
Arm: 1.27 m Bucket: 0.11 m ³ ISO 7451 Rubber shoes: 300 mm	3 m					0.40	*0.40	4.55	
	2 m		*0.71	*0.71	0.48	*0.64	0.34	*0.40	4.93
	1 m		0.72	*1.10	0.46	*0.76	0.32	*0.43	5.01
	Ground		0.69	*1.34	0.45	*0.87	0.34	*0.50	4.81
	- 1 m	1.33	*1.94	0.68	*1.30	0.44	*0.85	0.41	*0.65

Notes: 1. Rating are based on SAE J1097.

2. Lifting capacity of the ZAXIS Series does not exceed 75% of tipping load with the machine on firm, level ground or 87% full hydraulic capacity.

3. The load point is a hook (not standard equipment) located on the back of the bucket.

4. *Load limited by hydraulic capacity.



Head office: 5-1 Koraku 2-chome, Bunkyo-ku
Tokyo 112-8563, Japan

Telephone: (03)3830-8050

Facsimile: (03)3830-8204

The Specifications include data that are not applicable to certain areas.
Optional equipment may vary with territory specifications.
Specifications are subject to change without notice.

KS-E416R

Printed in Japan 03.10 (KA/KA, MT₃)