

ZAXIS-3 series

HITACHI

ZAXIS
280



HYDRAULIC EXCAVATOR

- **Model Code** : ZX280LC-3 / ZX280LCN-3
- **Engine Rated Power** : 140 kW (190 PS)
- **Operating Weight** : ZX280LC-3: 28 800 – 32 200 kg
ZX280LCN-3: 28 600 – 32 000 kg
- **Backhoe Bucket** : SAE, PCSA Heaped: 0.91 – 1.38 m³
CECE Heaped: 0.83 – 1.21 m³

The Power to Perform

The ZAXIS-3 series are a new generation of excavators designed to provide more efficient power, productivity and improved operator comfort. By listening carefully to the wishes of the end-user, HITACHI not only understands your business, but also provides the reliable solutions you've been looking for.

NEW AND IMPROVED

- **Performance:**
17% higher production
- **Comfort:**
Excellent visibility
Enhanced controllability
Lower noise level
- **New equipment:**
Standard satellite communication system
Standard rear view camera
Standard theft deterrent system
- **Reduced running costs:**
Lower fuel consumption per m³
Improved durability and reliability



Productivity

New E-mode
New hydraulic system HIOS III
Hydraulic boosting system
Enhanced boom circulation system
New electronic controlled diesel engine

Page 4-5

Operator comfort

High visibility inside cab
Short stroke levers
Wide foot space
Comfort designed seat
Improved controllability and operator comfort

Page 6-7

Multi function monitor

Maintenance support
Attachment support system
Rear-view camera
Theft deterrent system
Fuel consumption monitoring

Page 8-9

Durability and reliability

Strengthened X beam
Strengthened undercarriage
Improved idler brackets
Strengthened front attachment

Page 10-11

Maintenance

Conveniently located inspection points
Parallel arrangement of the cooling pack
Simplified cleaning of undercarriage
Extended oil and filter change intervals

Page 12-13

Safety measures

CRES II cab
Engine shut-off switch
Pilot control shut-off lever
Cab right guard
Evacuation hammer

Page 14

Environment measures

Array of low noise mechanisms
Ecological design

Page 15

Parts & Service

Parts centre
Service

Page 16

e-Service Owner's site

Page 17

Specifications

Page 18-27

- **The new engine complies with the Emission Regulations Stage III A**
- **The advanced low noise design complies with the coming EU noise regulation 2000 / 14 / EC, STAGE II**





Boosted Productivity

New hydraulic system HIOS III and new OHC 4-valve diesel engine were developed for ZAXIS-3. These advanced technologies are at work to yield bigger output with higher fuel efficiency.

More production, less fuel consumption

Increased Production

A combination of the hydraulic system (HIOS^{III}) and new OHC^{**} 4-valve engine allows the efficient use of hydraulic pressure to increase speeds of actuators and boost production with higher fuel efficiency. The productivity is increased with 17% in comparison to previous model ZAXIS-1.

**Human & Intelligent Operation System*

***OverHead Camshaft*

New E-mode

The new E mode, H/P mode and P mode can be selected to suit job needs. The new E mode can save fuel consumption 10% more than the previous P mode, while yielding similar production.

Increase in Swing Torque and Digging Force

Swing torque and digging force are increased significantly.

- Swing torque 10% UP

- Digging force 14% UP

Travelling High Power Mode;

At climbing or steering, when the machine needs more travel speed, the engine power automatically increases which makes the machine faster.

Efficient hydraulic control - HIOS III

ZAXIS-1 adapted HIOS II hydraulic system that is suitable for fine controllability by the operators. Continuously HITACHI developed new advanced hydraulic technology HIOS III for ZAXIS-3. In addition to the fine controllability this new system increases the efficiency of hydraulic circuit and increases speed of actuators.

The Hydraulic Boosting System

In arm roll-in and boom-raise operation, excess pressure oil is delivered from boom cylinder rod side to arm cylinder bottom side to increase flow rate for higher arm roll-in speed with 20%. Excess pressure oil from boom cylinder rod side is delivered to arm cylinder bottom side through a regenerative valve to increase flow rate for productive operation.

Enhanced Boom Recirculation System

In combined operation of boom and arm, pressure oil from boom cylinder bottom side is delivered to boom cylinder rod side, assisted by boom weight, for boom lowering. At the same time, pressure oil from the pump is delivered to the arm cylinder for arm movement. This mechanism allows an increase of speed in combined operation of 15%.

Development concept of new engine

OHC 4-Valve Engine

The new OHC 4-valve diesel engine is developed and built to comply with the rigorous Emission Regulations enforced in 2006 in EU. This new engine contributes to environmental preservation. At the same time it realizes high durability and low fuel consumption by adapting the latest advanced engine technology.



Common Rail Type Fuel Injection System

Electronic control common rail type fuel injection system drives an integrated fuel pump at an ultrahigh pressure to distribute fuel to each injector per cylinder through a common rail. This enables optimum combustion to generate big horsepower, and reduce PM* (diesel plume) and fuel consumption.

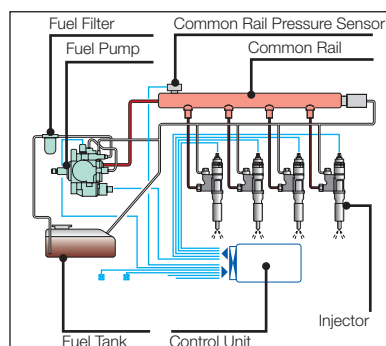

Cooled EGR** System

Exhaust gas is partially mixed with suction air to lower combustion temperature for reducing NOx. What's more, the EGR cooler cools down exhaust gas to increase air concentration for complete combustion, reducing PM* (diesel plume).

**Particulate Matter*

***Exhaust Gas Recirculation*

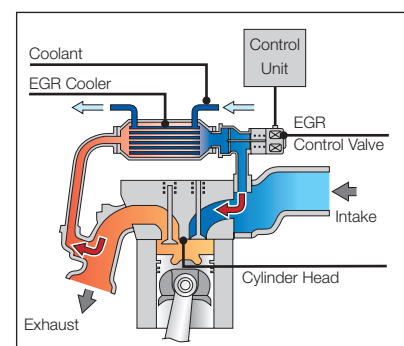

A New Standard in Operator Comfort

The operator's seat of the ZAXIS-3 series gives the operator an excellent view of the jobsite. On the widescreen colour LCD monitor the operator can see what is behind the machine. Ample legroom, short stroke levers and a large seat ensure optimum working conditions for the operator during long hours.





The ZAXIS-3 series cab has been redesigned to meet demands of European customers. From the operator's seat the operator has an excellent view of the jobsite. On the widescreen colour LCD monitor the operator can see machine conditions and with the rear view camera, what is behind the machine. Ample legroom, short stroke levers and a suspension seat with heating ensure optimum working conditions. The seat features horizontal, vertical and weight adjustments and has a backrest contoured for comfort, with a HITACHI logo.



Wide adjustable armrests and a retractable seat belt are included. Short stroke levers mean fingertip control of hydraulics and allow for continuous operation with less fatigue. Three switches on the lever (optional) can be set to operate attachments other than buckets. The cab is pressurized to keep out dust. Noise and vibrations are kept to a minimum due to the elastic mounts, filled with silicone oil, the cab rests on.

Visibility is improved especially for the right downward view. A large overhead window allows natural light to enter the cab. Sliding windows on the front and side enable direct communication between operator and other workers. Foot space has increased and breaker pedals have been redesigned for easier operation. A flat floor allows for easy cleaning. Ergonomic controls and switches, fully automatic air conditioner and a radio complete the package.

Embedded Information Technology

The ZAXIS-3 series is equipped with a widescreen colour LCD monitor with adjustable contrast for day and night shifts. With the monitor the operator can check maintenance intervals, select work modes, monitor fuel consumption, and connect to the rear-view camera. A theft deterrent system and multi-language selection is also available.

Multi function monitor



The colour LCD monitor, located in the cab, indicates coolant temperature, fuel level, and maintenance data. It also allows one-touch adjustment of the attachment. The display can also be adjusted to day or night shift.

Maintenance support

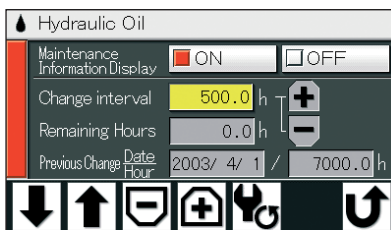
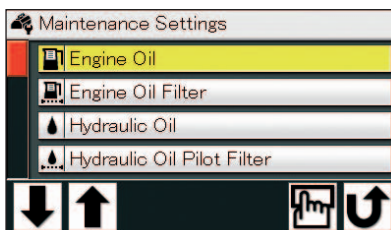

Replacement timing of hydraulic oil and fuel filters is alerted to the operator through the LCD monitor according to the schedule preset by the user each time when turning the key switch. The scheduled maintenance can prevent the failure of the machine.

Attachement support system (work mode selector)

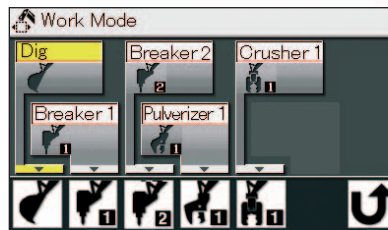

When replacing the attachment, oil flow adjustment can automatically be done by one touch on the work mode selection display on the LCD monitor. Minor adjustments of oil flow is possible if necessary.

Multilanguage selection



The monitor enables you to select 12 European languages.





Theft deterrent system

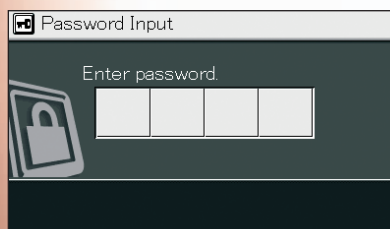

The electronic immobiliser requires the entry of an encryption code to the multifunctional monitor each time when starting the engine to prevent theft and vandalism.

Rear view camera



The widescreen colour LCD can also provide a view to the rear of the machine. Enhanced safety during swinging and travelling is the key advantage.

The rear view camera, which is located on the counterweight, can be switched on manually using the selection switch on the monitor. In addition, this feature is automatically activated during machine travel.

Fuel consumption monitoring

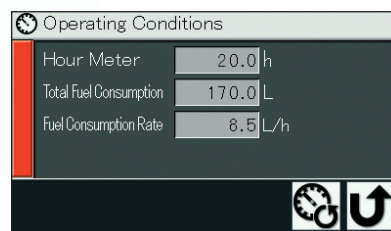

Fuel consumption per operating hour is computed, and the result is displayed on the LCD monitor. This information suggests refuelling timing, and guides energy-saving operation and efficient job management.

A Solid Base for a Long Life

HITACHI's technology is built on a wealth of experience and know-how from limestone sites and quarries around the world. The undercarriage of the ZAXIS 280 has become much stronger. Improved construction and enlarged box sections, a track undercover plate that protects the center joint and hydraulic hoses make this machine more durable.



Strengthened undercarriage

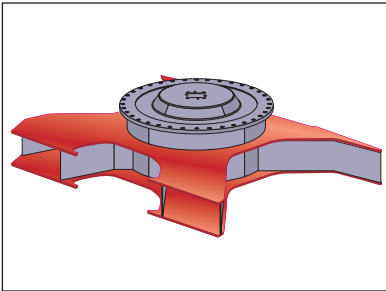

The X-beam is strengthened by the improved construction and enlarged box sections. The section is increased in strength up to 35%. Top and bottom plates of the X-beam use monolithic plates, instead of conventional welded four plates. This eliminates welding to strengthen the X-beam. Upper and lower rollers and upper roller brackets are increased in size for higher durability. Track links are thickened and reshaped for higher durability and rigidity.

Improved idler brackets

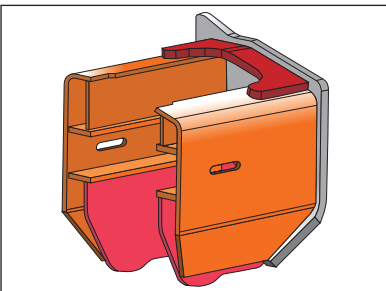

The idler bracket reinforcing plate is thickened greatly for higher durability to prevent the opening of idler bracket. The track link disengagement preventive plate, located just behind the idler bracket, is thickened for higher durability, and reshaped by extending its stepped end to prevent the disengagement of track links.

Strengthened front attachment

The boom top bracket is strengthened by using high-tensile steel. At arm-bucket joint, the arm top is hardened with Tungsten-Carbide thermal spraying for greater wear resistance at its contact surface with bucket, reducing jerking. Reinforced resin thrust plates designed to reduce noise and resist wear.

The new HN bushings, containing HITASOL (solid molybdenum-based lubricant), are utilized at the boom-arm joint and arm cylinder mounting area for better lubrication and higher durability. (At other joints, conventional HN bushings are also utilized.)

The boom foot is enlarged for higher strength. This improvement increases the durability and reliability under heavy-duty operation.



Simplified Maintenance

The ZAXIS-3 series meet customer demands for simplified maintenance. Regular maintenance is the key for keeping equipment in top condition, which can help to prevent costly downtime. In addition, a regular serviced machine has higher residual value. There are many service features to be found on the ZAXIS-3 series.



Conveniently located inspection points

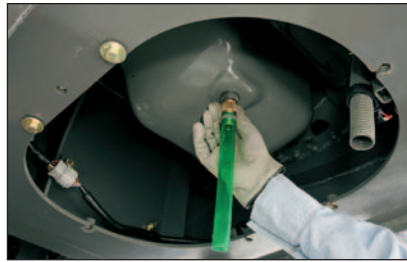
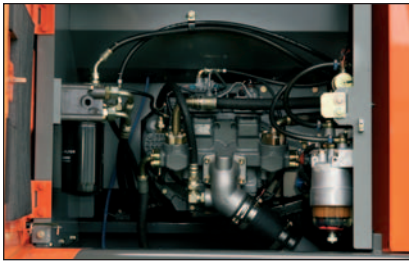

Wide doors give access, from ground level, to the fuel filter, water separator and engine oil filter. A large handrail, steps and anti-skid plates lead to the engine cover. The engine oil pan is fitted with a drain coupler. When draining, an associated drain hose is connected to the drain coupler. The drain coupler is reliable, avoiding oil leakage and vandalism.

The fresh air filter for the air conditioner is relocated to cab door side from conventional location behind the operator seat. This allows easy cleaning and replacement of the fresh air filter, like the air circulation filter inside the cab.

Parallel arrangement of the cooling pack

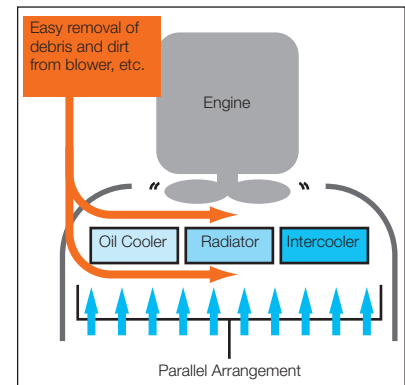

The oil cooler, radiator and intercooler are laid out in a parallel arrangement, instead of the conventional in-line arrangement. This parallel arrangement is significantly easier to clean around the engine. The air conditioner condenser can be opened for easy cleaning of the condenser and the radiator located behind.

Extended oil and filter change intervals

Front Pin Lubricating Intervals and Consumables Replacement		NEW ZAXIS 280
Lubricant	Bucket	250
	Boom Foot	500
	Front	500
Consumables	Engine Oil	500
	Engine Oil Filter	500
	Hydraulic Oil	5 000
	Hydraulic Oil Filter	1 000
	Fuel Filter	500

The oil and filter change intervals have been extended considerably, reducing maintenance time and expenses. Engine oil consumption is lower, and engine oil change is necessary every 500 hours. Hydraulic oil can be used up to 5 000 hours. The hydraulic oil filter can be used, up to 1 000 hours.

Safety Features

Ensuring the safety of the operator and other workers on the jobsite is an important concern for HITACHI. That is why the ZAXIS-3 series has a number of safety features including a new reinforced cab and shut-off mechanisms for engine and pilot controls.



CRES II cab

The CRES II cab is designed to help with “just in case” protection for the operator. Safety in case of tipping is improved. The cab top, for instance, can withstand about 4 times conventional load when side load is applied to the cab top until its deformation reaches 200 mm.

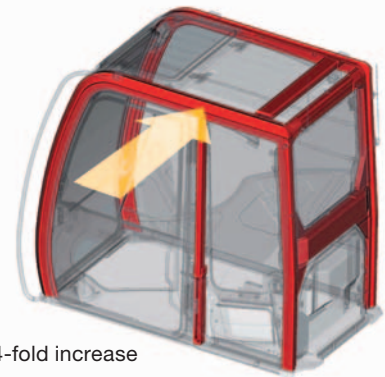

Withstanding load : 4-fold increase

Additional features

Cab right guard



Evacuation hammer



Engine shut-off switch



Pilot control shut-off lever



FOPS guard



(optional)

Retractable seat belt



Other features include a retractable seatbelt, evacuation hammer and emergency engine shut-off switch. A shut-off lever for pilot control helps to prevent unintentional movements. In addition a Falling Object Protective Structure (FOPS) guard is optionally available. For the cab windows there is a choice of laminated or tempered glass.

Environmental Features

HITACHI takes its responsibility when it comes to the environment. Our production facilities have ISO 14001 certification. The HITACHI machine is lead free and has a low-noise design, therefore HITACHI customers get one of the most environmentally considerate hydraulic excavators available today.

A cleaner machine

The ZAXIS-3 series is equipped with a clean but powerful engine to comply with Stage III A. An engine emission regulations effective in the European Union from 2006. Exhaust gas is partly re-combusted to reduce particulate matter (PM) output and lower nitrogen oxide (NOx) levels.



A quieter machine

A number of features make this machine quieter. First, isochronous control of the engine speed means a restriction of engine speed during no-load and light-duty operation to suppress sound. A fan with curved blades reduces air resistance and air flow noise. Third, a time-tested muffler suppresses engine noise significantly and reduces emissions.



A recyclable machine

Over 97% of the ZAXIS-3 series can be recycled. All resin parts are marked to facilitate recycling. The machine is completely leadfree. The radiator and oil cooler are made from aluminium and all wires are lead-less. In addition, biodegradable hydraulic oil is available for jobsites where special environmental care is required.





Parts & Service

Over the years, we have gained experience in one of the most competitive service markets in the world - Japan. Using our know-how in dealing directly with customers, we have created a worldwide support system that is highly capable.

Parts

HITACHI only offers genuine high quality parts. We guarantee that these parts have high performance and long life. We manage around 1 000 000 types of parts all around the world. They are designed and built to be the best match for your HITACHI equipment. HITACHI has a global parts distribution network that makes sure you get what you need

as quickly as possible. We have more than 150 dealers worldwide who provide the closest support for your needs. In most cases, your dealer will have the replacement part that you require. If a dealer does not have a certain part, he can order it from four fully-stocked parts depots located across the world. These distribution centres are all con-

nected by an online system that gives them access to shared information on stocks, such as the number and type of available parts. The depots, which in turn are stocked by a parts centre in Japan, minimize delivery time and enable you to get your parts as efficiently and quickly as possible.

Service

Our goal is to “keep customer equipment at a maximum performance level”. To fulfil this goal, we have set more than 150 dealers all over the world. They have highly trained technicians, and provide a number of support programs. HITACHI provides a unique extended warranty program called HITACHI Extended Life Program, or HELP.

To minimize downtime during troubleshooting, we developed a PDA based diagnostic system called “Dr.ZX”. To keep our customers’ equipment in top running shape, good service is indispensable. We believe personnel training is the key to providing the best service.

If you would like more information regarding parts and/or service, please ask your nearest HITACHI dealer. Not all programs and/or services are available in every market or region.

Remote fleet management with e-Service Owner's Site

Reduce maintenance effort and costs for your machine fleet with e-Service Owner's Site; latest machine information of each of your machines available on-line, in your office.



e-Service Owner's Site features

Operation

Remote access to all relevant machine operation information such as daily operating hours and machine fuel level as well as historically cumulated temperatures and pressures.

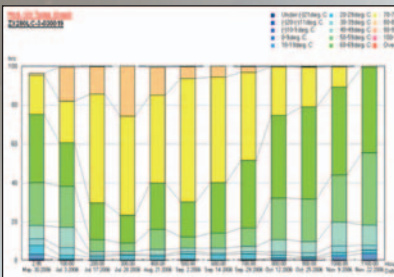

Maintenance

For each machine, maintenance history as well as recommended maintenance due is displayed in one view, allowing for accurate and efficient fleet maintenance management.

Item	Due date	Current status	Remarks
Oil change	2008/03/15	Completed	
Hydraulic oil change	2008/03/15	Completed	
Filter change	2008/03/15	Completed	
...

Location

In addition to any general GPS function, GIS (Geographical Information System) will not only show the geographical position of each machine with immediate serial number identification, it will also allow for dedicated multiple machine searches using specific operational information as search criteria.

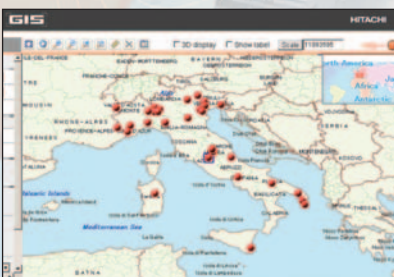

Check and monitor each of your machines from your office

Enhanced service support from your local dealer

Actual geographical location of each of your machines

e-Service Owner's Site is an on-line fleet management tool offered by HCME to each of its customers. It will present all operational information and location of your machines on a PC in your office, giving you an up to date overview of your machines, allowing for full fleet control. Each machine will regularly send its operational data to a satellite and from there, via a ground station to a Hitachi server. The data collected in the server will then be processed and directed to each customer around the world. Your machine information will be available through a secure internet connection for you and your dealer. This communication chain is operational 24h a day, each day of the year. It will support your job planning, help you maintain your machine and allow for enhanced service and trouble shooting support by your local dealer, all directly contributing to reduce downtime and increase the cost performance of your fleet.

All new ZAXIS-3 and ZW machines supplied by HCME will have a satellite communication unit installed as standard*, meaning each owner can directly enjoy the benefits of e-Service Owner's Site. Your local dealer will be able to give you access to e-Service Owner's Site.

- Optimizing fleet management
- Accurate maintenance planning
- Job planning support tool
- Swift trouble shooting

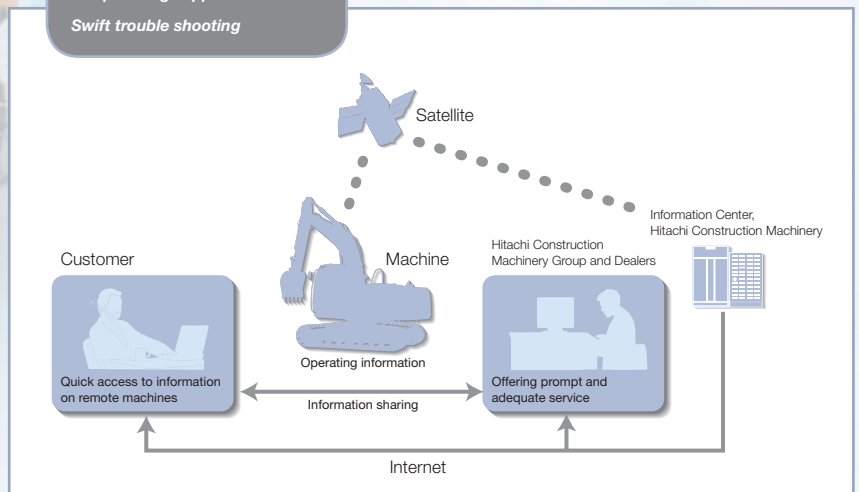

* (1) Satellite communication may be forbidden by the local regulatory standards (including safety standards) and legal requirements of the particular country where you wish to use it. Please contact HITACHI dealer for details.
 (2) Satellite communication basically allows for worldwide coverage. Contact your local dealer for the latest situation on actual satellite communication availability for your country or specific jobsite.
 (3) If transmission of the satellite signal is hindered in any way, satellite communication may not be possible.

ENGINE

Model	Isuzu AH-4HK1X
Type	4-cycle water-cooled, direct injection
Aspiration	Turbocharged, intercooled
No. of cylinders	4
Rated power	
ISO 9249, net	140 kW (188 HP) at 2 100 min ⁻¹ (rpm)
ECC 80/1269, net	140 kW (188 HP) at 2 100 min ⁻¹ (rpm)
SAE J1349, net	140 kW (188 HP) at 2 100 min ⁻¹ (rpm)
Maximum torque	676 N.m (69 kgf.m) at 1 500 min ⁻¹ (rpm)
Piston displacement	5.193 L
Bore and stroke	115 mm x 125 mm
Batteries	2 x 12 V / 88 Ah
Governor	

HYDRAULIC SYSTEM

- Work mode selector
Digging mode / Attachment mode
 - Engine speed sensing system
- | | |
|------------------------|--|
| Main pumps | 2 variable displacement axial piston pumps |
| Maximum oil flow | 2 x 227 L/min |
| Pilot pump | 1 gear pump |
| Maximum oil flow | 34 L/min |

Hydraulic Motors

Travel	2 variable displacement axial piston motors
Swing	1 axial piston motor

Relief Valve Settings

Implement circuit	34.3 MPa (350 kgf/cm ²)
Swing circuit	32.4 MPa (300 kgf/cm ²)
Travel circuit	34.3 MPa (350 kgf/cm ²)
Pilot circuit	3.9 MPa (40 kgf/cm ²)
Power boost	36.3 MPa (370 kgf/cm ²)

Hydraulic Cylinders

High-strength piston rods and tubes. Cylinder cushion mechanisms provided in boom and arm cylinders to absorb shock at stroke ends.

Dimensions

	Quantity	Bore	Rod diameter
Boom	2	135 mm	95 mm
Arm	1	150 mm	105 mm
Bucket	1	135 mm	90 mm
Positioning	1	150 mm	100 mm

Hydraulic Filters

Hydraulic circuits use high-quality hydraulic filters. A suction filter is incorporated in the suction line, and full-flow filters in the return line and swing/travel motor drain lines.

CONTROLS

Pilot controls. HITACHI's original shockless valve.	
Implement levers	2
Travel levers with pedals	2

UPPERSTRUCTURE

Revolving Frame

Welded sturdy box construction, using heavy-gauge steel plates for ruggedness. D-section frame for resistance to deformation.

Swing Device

Axial piston motor with planetary reduction gear is bathed in oil. Swing circle is single-row, shear-type ball bearing with induction-hardened internal gear. Internal gear and pinion gear are immersed in lubricant. Swing parking brake is spring-set/hydraulic-released disc type.

Swing speed	12.6 min ⁻¹ (rpm)
-------------------	------------------------------

Operator's Cab

Independent spacious cab, 1 005 mm wide by 1 675 mm high, conforming to ISO* Standards. Reinforced glass windows on 4 sides for visibility. Front windows (upper and lower) can be opened. Reclining seat with armrests; adjustable with or without control levers.

* International Standardization Organization

UNDERCARRIAGE

Tracks

Tractor-type undercarriage. Welded track frame using selected materials. Side frame welded to track frame. Lubricated track rollers, idlers, and sprockets with floating seals.

Track shoes with triple grousers made of induction-hardened rolled alloy. Heat-treated connecting pins with dirt seals. Hydraulic (grease) track adjusters with shock-absorbing recoil springs.

Numbers of Rollers and Shoes on Each Side

Upper rollers	2
Lower rollers	8
Track shoes	48
Track guard	1

Travel Device

Each track driven by 2-speed axial piston motor through planetary reduction gear for counterrotation of the tracks. Sprockets are replaceable. Parking brake is spring-set/hydraulic-released disc type. Travel shockless relief valve built in travel motor absorbs shocks when stopping travel.

Automatic transmission system: High-Low.

Travel speeds	High : 0 to 5.5 km/h
	Low : 0 to 3.3 km/h

Maximum traction force	246 kN (25 100 kgf)
Gradeability	35° (70%) continuous

WEIGHTS AND GROUND PRESSURE

ZAXIS 280LC WITH MONOBLOCK BOOM:

Equipped with 6.20 m monoblock boom, 3.11 m arm and 1.10 m³ bucket (SAE,PSCA heaped), 6 100 kg counterweight.

Shoe type	Shoe width	Operating weight	Ground pressure
Triple grouser	600 mm	28 200 kg	53 kPa (0.54 kgf/cm ²)
	700 mm	28 800 kg	46 kPa (0.47 kgf/cm ²)
	800 mm	29 100 kg	41 kPa (0.42 kgf/cm ²)
	900 mm	29 900 kg	37 kPa (0.38 kgf/cm ²)

ZAXIS 280LCN WITH MONOBLOCK BOOM:

Equipped with 6.20 m monoblock boom, 3.11 m arm and 1.10 m³ bucket (SAE,PSCA heaped), 6 100 kg counterweight.

Shoe type	Shoe width	Operating weight	Ground pressure
Triple grouser	600 mm	28 000 kg	52 kPa (0.54 kgf/cm ²)
	700 mm	28 600 kg	46 kPa (0.47 kgf/cm ²)
	800 mm	29 000 kg	41 kPa (0.42 kgf/cm ²)
	900 mm	29 800 kg	37 kPa (0.38 kgf/cm ²)

ZAXIS 280LC WITH 2-PIECE BOOM:

Equipped with 2-piece boom, 3.11 m arm and 1.10 m³ bucket (SAE,PSCA heaped), 6 500 kg counterweight.

Shoe type	Shoe width	Operating weight	Ground pressure
Triple grouser	600 mm	28 500 kg	53 kPa (0.54 kgf/cm ²)
	700 mm	29 100 kg	47 kPa (0.48 kgf/cm ²)
	800 mm	29 400 kg	41 kPa (0.42 kgf/cm ²)
	900 mm	29 800 kg	37 kPa (0.38 kgf/cm ²)

ZAXIS 280LCN WITH 2-PIECE BOOM:

Equipped with 2-piece boom, 3.11 m arm and 1.10 m³ bucket (SAE,PSCA heaped), 6 500 kg counterweight.

Shoe type	Shoe width	Operating weight	Ground pressure
Triple grouser	600 mm	28 300 kg	53 kPa (0.54 kgf/cm ²)
	700 mm	28 900 kg	46 kPa (0.48 kgf/cm ²)
	800 mm	29 300 kg	41 kPa (0.42 kgf/cm ²)
	900 mm	29 700 kg	37 kPa (0.38 kgf/cm ²)

Weights of the basic machines [including 6 100 kg counterweight and triple grouser shoes, excluding front-end attachment, fuel, hydraulic oil, engine oil and coolant etc.] are:

ZAXIS 280LC 22 000 kg with 600 mm shoes
 ZAXIS 280LCN 21 800 kg with 600 mm shoes

SERVICE REFILL CAPACITIES

Fuel tank	500.0 L
Engine coolant	26.0 L
Engine oil	23.0 L
Swing device	11.7 L
Travel device	9.2 L
(each side)	
Hydraulic system	290.0 L
Hydraulic oil tank	243.0 L

BACKHOE ATTACHMENTS

Boom and arms are of welded, box-section design. 6.20 m monoblock boom, 2-piece boom and 2.42 m, 3.11 m and 3.76 m arms are available.

BUCKETS

Capacity SAE, PCSA heaped	Capacity CECE heaped	Width without side cutters	Weight
0.91 m ³	0.83 m ³	1 000 mm	792 kg
1.03 m ³	0.92 m ³	1 100 mm	873 kg
1.14 m ³	1.02 m ³	1 200 mm	892 kg
1.38 m ³	1.21 m ³	1 400 mm	1 012 kg

DIMENSIONS : MONOBLOCK BOOM

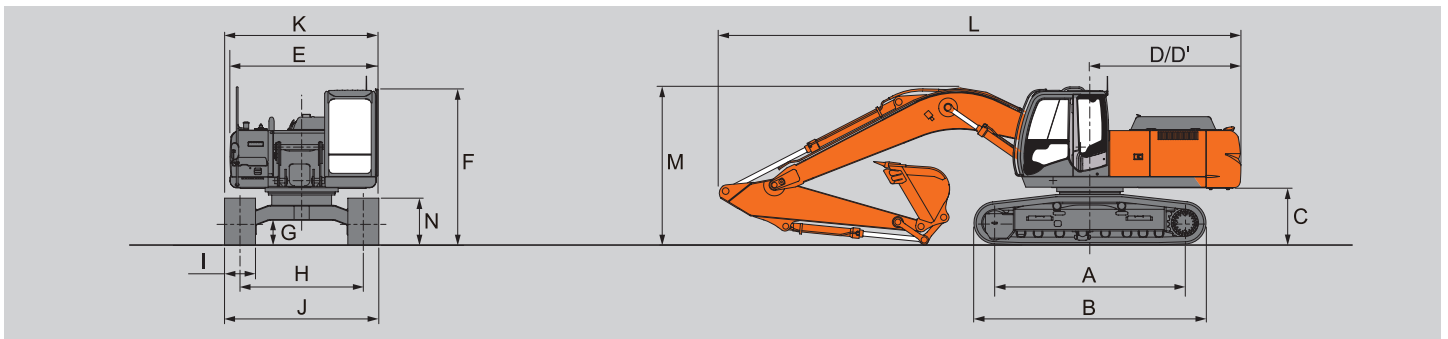

Unit: mm

	ZAXIS 280LC	ZAXIS 280LCN
A Distance between tumblers	4 052	4 052
B Undercarriage length	4 940	4 940
*C Counterweight clearance	1 180	1 180
D Rear-end swing radius	2 940	2 940
D' Rear-end length	2 940	2 940
E Overall width of upperstructure	2 890	2 890
F Overall height of cab	3 100	3 100
*G Min. ground clearance	510	510
H Track gauge	2 590	2 400
I Track shoe width	G 600	G 600
J Undercarriage width	3 190	3 000
K Overall width	3 190	3 000
L Overall length		
With 2.42 m arm	10 440	10 440
With 3.11 m arm	10 340	10 340
M Overall height of boom		
With 2.42 m arm	3 410	3 410
With 3.11 m arm	3 170	3 170
N Track height with triple grouser shoes	920	920

* Excluding track shoe lug G: Triple grouser shoe

WORKING RANGES

Unit: mm

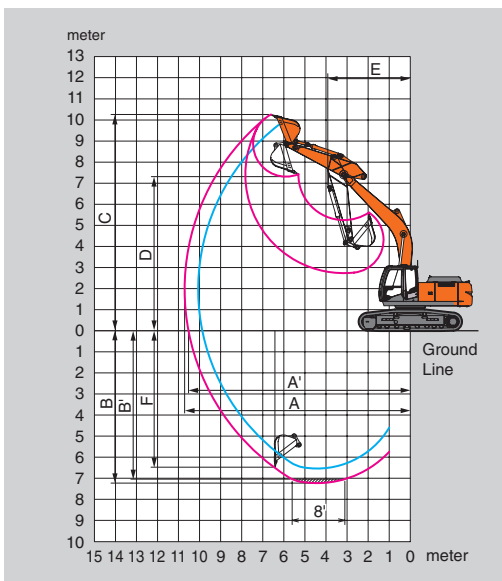

	ZAXIS 280LC / ZAXIS 280LCN	
	6.20 m Mono boom	
Arm length	2.42 m	3.11 m
A Max. digging reach	10 060	10 710
A' Max. digging reach (on ground)	9 870	10 520
B Max. digging depth	6 540	7 230
B' Max. digging depth (8' level)	6 320	7 050
C Max. cutting height	9 890	10 260
D Max. dumping height	6 970	7 310
E Min. swing radius	4 070	3 910
F Max. vertical wall	5 650	6 480
Bucket digging force** ISO	193 kN (19 700 kgf)	193 kN (19 700 kgf)
Bucket digging force** SAE : PCSA	167 kN (17 000 kgf)	167 kN (17 000 kgf)
Arm crowd force** ISO	174 kN (17 000 kgf)	137 kN (14 000 kgf)
Arm crowd force** SAE : PCSA	165 kN (16 800 kgf)	132 kN (13 500 kgf)

Excluding track shoe lug ** At power boost

DIMENSIONS : 2-PIECE BOOM

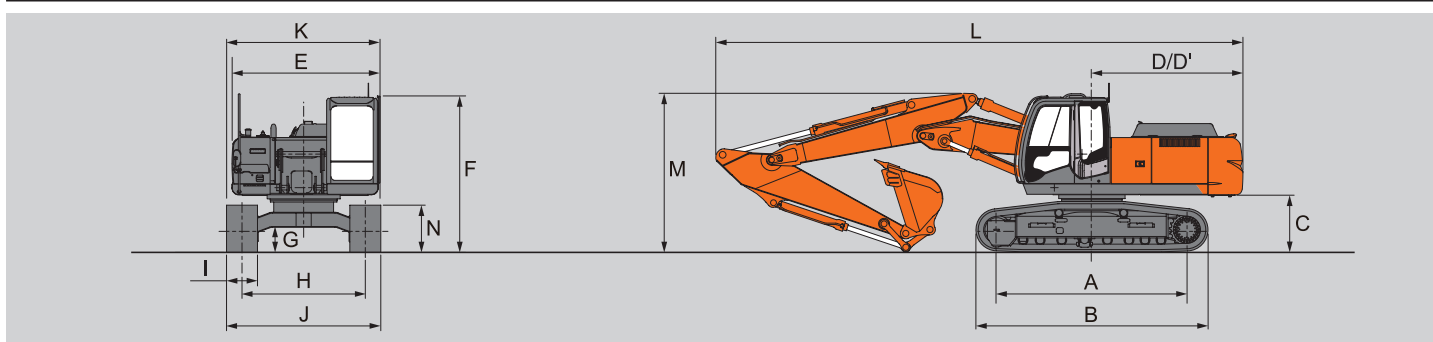

Unit: mm

	ZAXIS 280LC	ZAXIS 280LCN
A Distance between tumblers	4 052	4 052
B Undercarriage length	4 940	4 940
*C Counterweight clearance	1 180	1 180
D Rear-end swing radius	2 940	2 940
D' Rear-end length	2 940	2 940
E Overall width of upperstructure	2 890	2 890
F Overall height of cab	3 100	3 100
*G Min. ground clearance	510	510
H Track gauge	2 590	2 400
I Track shoe width	G 600	G 600
J Undercarriage width	3 190	3 000
K Overall width	3 190	3 000
L Overall length		
With 2.42 m arm	10 330	10 330
With 3.11 m arm	10 300	10 300
M Overall height of boom		
With 2.42 m arm	3 220	3 220
With 3.11 m arm	3 150	3 150
N Track height with triple grouser shoes	920	920

* Excluding track shoe lug G: Triple grouser shoe

WORKING RANGES

Unit: mm

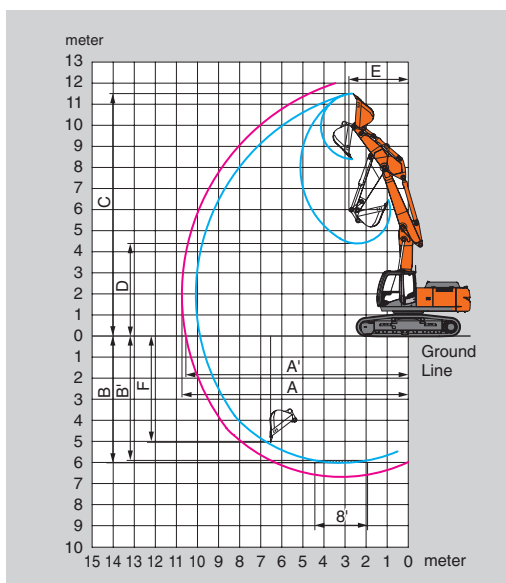

	ZAXIS 280LC / ZAXIS 280LCN	
	2-piece boom	
Arm length	2.42 m	3.11 m
A Max. digging reach	10 070	10 740
A' Max. digging reach (on ground)	9 880	10 550
B Max. digging depth	6 020	6 690
B' Max. digging depth (8' level)	5 910	6 590
C Max. cutting height	11 500	12 080
D Max. dumping height	8 390	8 960
E Min. swing radius	2 820	2 580
F Max. vertical wall	5 040	5 780
Bucket digging force** ISO	193 kN (19 700 kgf)	193 kN (19 700 kgf)
Bucket digging force** SAE : PCSA	167 kN (17 000 kgf)	167 kN (17 000 kgf)
Arm crowd force** ISO	174 kN (17 000 kgf)	137 kN (14 000 kgf)
Arm crowd force** SAE : PCSA	165 kN (16 800 kgf)	132 kN (13 500 kgf)

Excluding track shoe lug ** At power boost

LIFTING CAPACITIES

Metric measure

- Notes: 1. Ratings are based on ISO 10567.
 2. Lifting capacity of the ZAXIS Series does not exceed 75% of tipping load with the machine on firm, level ground or 87% full hydraulic capacity.
 3. The load point is the center-line of the bucket pivot mounting pin on the arm.
 4. *Indicates load limited by hydraulic capacity.
 5. 0 m = Ground.

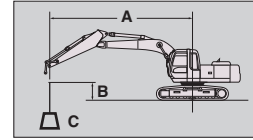

A: Load radius
 B: Load point height
 C: Lifting capacity

ZAXIS 280LC MONO BLOCK BOOM

Rating over-front

Rating over-side or 360 degrees

Unit: kg

Conditions	Load point height	Load radius										At max. reach				
		3.0 m		4.5 m		6.0 m		7.5 m		9.0 m				meter		
Boom 6.2 m Arm 2.42 m Shoe 600 mm Counterweight 6 100 kg	6.0 m													*6 740	5 440	7.46
	4.5 m			*9 590	*9 590									*6 870	4 670	8.11
	3.0 m			*12 340	10 580	*8 950	7 060							6 860	4 290	8.44
	1.5 m					*10 050	6 730	8 050	4 950					6 700	4 160	8.49
	0			*14 720	9 810	*10 690	6 530	7 920	4 840					6 900	4 250	8.27
	-1.5 m	*10 360	*10 360	*14 390	9 830	*10 750	6 480	7 900	4 820					7 560	4 640	7.75
	-3.0 m	*18 020	*18 020	*13 290	9 980	*10 040	6 580							*8 470	5 530	6.86
	-4.5 m	*14 540	*14 540	*10 790	10 340									*8 710	7 920	5.42
Boom 6.2 m Arm 3.11 m Shoe 600 mm Counterweight 6 100 kg	6.0 m					*5 960	*5 960	*5 910	5 520					*4 730	4 730	8.19
	4.5 m			*8 240	*8 240	*6 940	*6 940	*6 330	5 370					*4 730	4 140	8.78
	3.0 m			*11 000	10 940	*8 240	7 180	*6 990	5 170	*5 560	3 900			*4 890	3 830	9.09
	1.5 m			*13 310	10 180	*9 500	6 800	*7 690	4 970	6 130	3 800			*5 220	3 720	9.14
	0			*14 450	9 820	*10 380	6 540	7 900	4 810					*5 800	3 780	8.93
	-1.5 m	*10 250	*10 250	*14 590	9 730	*10 730	6 420	7 820	4 740					6 610	4 060	8.45
	-3.0 m	*16 480	*16 480	*13 930	9 820	*10 410	6 450	7 870	4 790					7 670	4 680	7.65
	-4.5 m	*16 970	*16 970	*12 190	10 070	*8 980	6 640							*8 170	6 120	6.39

Metric measure

- Notes: 1. Ratings are based on ISO 10567.
 2. Lifting capacity of the ZAXIS Series does not exceed 75% of tipping load with the machine on firm, level ground or 87% full hydraulic capacity.
 3. The load point is the center-line of the bucket pivot mounting pin on the arm.
 4. *Indicates load limited by hydraulic capacity.
 5. 0 m = Ground.

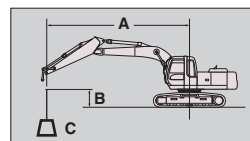

A: Load radius
 B: Load point height
 C: Lifting capacity

ZAXIS 280LCN MONO BLOCK BOOM

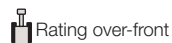

Unit: kg

Conditions	Load point height	Load radius										At max. reach				
		3.0 m		4.5 m		6.0 m		7.5 m		9.0 m		meter				
Boom 6.2 m Arm 2.42 m Shoe 600 mm Counterweight 6 100 kg	6.0 m													*6 740	4 990	7.46
	4.5 m			*9 590	*9 590									*6 870	4 270	8.11
	3.0 m			*12 340	9 550	*8 950	6 430							6 820	3 920	8.44
	1.5 m					*10 050	6 110	7 990	4 510					6 660	3 790	8.49
	0			*14 720	8 810	*10 690	5 920	7 870	4 400					6 850	3 870	8.27
	-1.5 m	*10 360	*10 360	*14 390	8 820	*10 750	5 870	7 850	4 390					7 510	4 220	7.75
	-3.0 m	*18 020	17 680	*13 290	8 970	*10 040	5 960							*8 470	5 030	6.86
	-4.5 m	*14 540	*14 540	*10 790	9 320									*8 710	7 190	5.42
Boom 6.2 m Arm 3.11 m Shoe 600 mm Counterweight 6 100 kg	6.0 m					*5 960	*5 960	*5 910	5 070					*4 730	4 340	8.19
	4.5 m			*8 240	*8 240	*6 940	*6 940	*6 330	4 930					*4 730	3 790	8.78
	3.0 m			*11 000	9 900	*8 240	6 550	*6 990	4 730	*5 560	3 550			*4 890	3 500	9.09
	1.5 m			*13 310	9 160	*9 500	6 180	*7 690	4 520	6 090	3 460			*5 220	3 390	9.14
	0			*14 450	8 820	*10 380	5 920	7 850	4 370					*5 800	3 440	8.93
	-1.5 m	*10 250	*10 250	*14 590	8 730	*10 730	5 810	7 770	4 300					6 570	3 690	8.45
	-3.0 m	*16 480	*16 480	*13 930	8 810	*10 410	5 830	7 820	4 350					7 620	4 250	7.65
	-4.5 m	*16 970	*16 970	*12 190	9 060	*8 980	6 030							*8 170	5 560	6.39

LIFTING CAPACITIES

Metric measure

- Notes: 1. Ratings are based on ISO 10567.
 2. Lifting capacity of the ZAXIS Series does not exceed 75% of tipping load with the machine on firm, level ground or 87% full hydraulic capacity.
 3. The load point is the center-line of the bucket pivot mounting pin on the arm.
 4. *Indicates load limited by hydraulic capacity.
 5. 0 m = Ground.

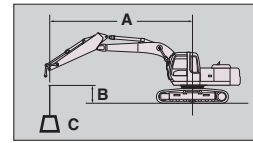

A: Load radius
 B: Load point height
 C: Lifting capacity

ZAXIS 280LC 2-PIECE BOOM

Rating over-front

Rating over-side or 360 degrees

Unit: kg

Conditions	Load point height	Load radius										At max. reach		
		3.0 m		4.5 m		6.0 m		7.5 m		9.0 m				meter
2-Piece Boom Arm 2.42 m Shoe 600 mm Counterweight 6 500 kg	9.0 m											*7 600	*7 600	4.65
	7.5 m											*5 680	*5 680	6.41
	6.0 m	*10 270	*10 270									*4 930	*4 930	7.47
	4.5 m	*14 010	*14 010	*9 660	*9 660							*4 590	*4 590	8.12
	3.0 m	*17 660	*17 660	*13 700	11 560	*7 850	7 580					*4 490	4 450	8.45
	1.5 m	*20 300	*20 300	*14 720	*11 480	*9 150	7 710	*6 100	5 190			*4 580	4 330	8.50
	0	*22 820	21 610	*14 760	11 180	*10 450	7 350	*6 900	5 120			*4 870	4 450	8.28
	-1.5 m	*23 320	21 300	*14 970	10 870	*10 860	7 070	*6 490	5 070			*5 470	4 860	7.76
	-3.0 m	*22 250	21 450	*14 250	10 750	*9 260	8 980					*5 970	5 870	6.83
2-Piece Boom Arm 3.11 m Shoe 600 mm Counterweight 6 500 kg	9.0 m			*7 040	*7 040							*5 800	*5 800	5.79
	7.5 m			*6 740	*6 740	*5 730	*5 730					*4 690	*4 690	7.27
	6.0 m			*7 220	*7 220	*5 840	*5 840	*4 980	*4 980			*4 170	*4 170	8.22
	4.5 m	*13 710	*13 710	*8 460	*8 460	*6 320	*6 320	*5 130	*5 130			*3 920	*3 920	8.81
	3.0 m	*17 730	*17 730	*11 390	*11 390	*7 200	*7 200	*5 480	5 480	*4 230	4 060	*3 840	*3 840	9.12
	1.5 m	*19 260	*19 260	*14 570	11 380	*8 440	7 850	*5 980	5 410	*4 500	3 980	*3 910	3 860	9.16
	0	*21 690	21 650	*14 650	11 370	*9 800	7 460	*6 530	5 250			*4 130	3 940	8.96
	-1.5 m	*23 070	21 370	*14 750	10 910	*10 760	7 160	*7 060	5 070			*4 570	4 250	8.48
	-3.0 m	*23 030	21 260	*14 960	10 770	*10 500	6 940	*6 460	5 060			*5 390	4 910	7.68
-4.5 m	*19 470	*19 470	*11 960	10 710							*7 070	*7 070	5.87	

Metric measure

- Notes: 1. Ratings are based on ISO 10567.
 2. Lifting capacity of the ZAXIS Series does not exceed 75% of tipping load with the machine on firm, level ground or 87% full hydraulic capacity.
 3. The load point is the center-line of the bucket pivot mounting pin on the arm.
 4. *Indicates load limited by hydraulic capacity.
 5. 0 m = Ground.

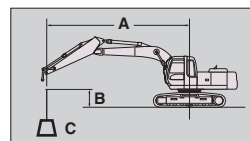

A: Load radius
 B: Load point height
 C: Lifting capacity

ZAXIS 280LCN 2-PIECE BOOM

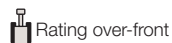

Unit: kg

Conditions	Load point height	Load radius										At max. reach		
		3.0 m		4.5 m		6.0 m		7.5 m		9.0 m		meter		
2-Piece Boom Arm 2.42 m Shoe 600 mm Counterweight 6 500 kg	9.0 m											*7 600	*7 600	4.65
	7.5 m											*5 680	*5 680	6.41
	6.0 m	*10 270	*10 270									*4 930	*4 930	7.47
	4.5 m	*14 010	*14 010	*9 660	*9 660							*4 590	4 420	8.12
	3.0 m	*17 660	*17 660	*13 700	10 640	*7 850	*7 050					*4 490	4 070	8.45
	1.5 m	*20 300	19 810	*14 720	10 730	*9 150	7 060	*6 100	4 740			*4 580	3 960	8.50
	0	*22 820	19 020	*14 760	10 130	*10 450	6 730	*6 900	4 680			*4 870	4 060	8.28
	-1.5 m	*23 320	18 730	*14 970	9 830	*10 860	6 440	*6 490	4 630			*5 470	4 440	7.76
	-3.0 m	*22 250	18 870	*14 250	9 710	*9 260	6 350					*5 970	5 350	6.83
2-Piece Boom Arm 3.11 m Shoe 600 mm Counterweight 6 500 kg	9.0 m			*7 040	*7 040							*5 800	*5 800	5.79
	7.5 m			*6 740	*6 740	*5 730	*5 730					*4 690	*4 690	7.27
	6.0 m			*7 220	*7 220	*5 840	*5 840	*4 980	*4 980			*4 170	*4 170	8.22
	4.5 m	*13 710	*13 710	*8 460	*8 460	*6 320	*6 320	*5 130	*5 130			*3 920	3 910	8.81
	3.0 m	*17 730	*17 730	*11 390	*10 670	*7 200	7 040	*5 480	5 130	*4 230	3 710	*3 840	3 620	9.12
	1.5 m	*19 260	*19 260	*14 570	10 440	*8 440	7 200	*5 980	5 010	*4 500	3 640	*3 910	3 530	9.16
	0	*21 690	19 410	*14 650	10 310	*9 800	6 820	*6 530	4 800			*4 130	3 600	8.96
	-1.5 m	*23 070	18 790	*14 750	9 870	*10 760	6 530	*7 060	4 630			*4 570	3 870	8.48
	-3.0 m	*23 030	18 690	*14 960	9 730	*10 500	6 310	*6 460	4 610			*5 390	4 480	7.68
-4.5 m	*19 470	18 950	*11 960	9 670							*7 070	6 590	5.87	

STANDARD EQUIPMENT

Standard equipment may vary by country, so please consult your HITACHI dealer for details.

ENGINE

- H/P mode control
- E mode control
- 50 A alternator
- Dry-type air filter with evacuator valve (with air filter restriction indicator)
- Cartridge-type engine oil filter
- Cartridge-type fuel double filters
- Air cleaner double filters
- Radiator and oil cooler with dust protective net
- Radiator reserve tank
- Fan guard
- Isolation-mounted engine
- Auto idle system
- Fuel cooler
- Electrical fuel feed pump
- Engine oil drain coupler

HYDRAULIC SYSTEM

- Work mode selector
- Power boost
- Auto power lift
- Boom-arm anti-drift valve
- Control valve with main relief valve
- Extra port for control valve
- Suction filter
- Full-flow filter
- Pilot filter
- Swing dampener valve

CAB

- CRES II (Center pillar reinforced structure) cab
- OPG top guard fitted Level I (ISO10262) compliant cab
- All-weather sound suppressed steel cab
- Equipped with reinforced, tinted (green color) glass windows
- 4 fluid-filled elastic mounts
- Front windows on upper, lower and left side can be opened
- Intermittent windshield wipers
- Front window washer
- Adjustable reclining seat with adjustable armrests
- Footrest
- Electric double horn
- AM-FM radio with digital clock
- Seat belt
- Drink holder
- Cigarette lighter
- Ashtray
- Storage box
- Glove compartment
- Fire extinguisher bracket
- Floor mat
- Short wrist control levers
- Pilot control shut-off lever
- Engine stop knob
- Auto control air conditioner
- Transparent roof with roll curtain
- Mechanical suspension seat with heater

MONITOR SYSTEM

- Display of meters: water temperature, hour, fuel rate, clock
- Other displays: work mode, auto-idle, glow, rearview monitor, operating conditions, etc
- Alarms: overheat, engine warning, engine oil pressure, alternator, minimum fuel level, hydraulic filter restriction, air filter restriction, work mode, overload, etc
- Alarm buzzers: overheat, engine oil pressure, overload

LIGHTS

- 2 working lights

UPPER STRUCTURE

- Undercover
- 6 100 kg counterweight
- Fuel level float
- Electric fuel refilling pump with auto stop
- Rearview camera
- 150 Ah batteries
- Hydraulic oil level gauge
- Tool box
- Utility space
- Rearview mirror (right & left side)
- Swing parking brake

UNDERCARRIAGE

- Travel parking brake
- Travel motor covers
- 1 track guard (each side) and hydraulic track adjuster
- Bolt-on sprocket
- Upper and lower rollers
- Reinforced track links with pin seals
- 4 tie down hooks

FRONT ATTACHMENTS

- HN bushing
- WC (tungsten-carbide) thermal spraying
- Reinforced resin thrust plate
- Flanged pin
- Casted bucket link A
- Centralized lubrication system
- Dirt seal on all bucket pins

MISCELLANEOUS

- Standard tool kit
- Lockable machine covers
- Lockable fuel refilling cap
- Skid-resistant tapes, plates and handrails
- Travel direction mark on track frame
- Onboard information controller

OPTIONAL EQUIPMENT

Optional equipment may vary by country, so please consult your HITACHI dealer for details.

CAB

- Laminated round glass window
- FOPS guard
- Air suspension seat with heater
- Rain guard
- Sun visor
- 12 V power source

LIGHTS

- Additional cab roof front lights
- Additional cab roof rear lights
- Rotating lamp
- Additional boom light with cover

UNDERCARRIAGE

- 3 track guards
- Track undercover

ATTACHMENTS

- Hammer and crusher piping
- Parts for hammer and crusher
- 2 pump combined flow assist piping
- Additional pump (30 L/min)
- Pilot accumulator
- High mesh full flow filter with restriction indicator
- Welded bucket link A with welded hook

OTHERS

- Hose rupture valve
- Overload warning device
- Pre-cleaner
- 6 500 kg heavy counterweight
- Biodegradable oil
- Louver cover

Designed to increase ventilation



- Tropical cover
Designed for use in the Tropics (severely hot climate), with extra wide opening for more heat dissipation, thus reducing sound suppression. The machine fitted with this cover cannot pass EU Noise Regulation 2000/14/ EC, STAGE II, not permitting the use of the CE mark

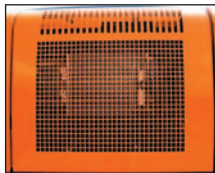

Prior to operating this machine, including satellite communication system, in a country other than a country of its intended use, it may be necessary to make modifications to it so that it complies with the local regulatory standards (including safety standards) and legal requirements of that particular country. Please do not export or operate this machine outside the country of its intended use until such compliance has been confirmed. Please contact your Hitachi dealer in case of questions about compliance.

These specifications are subject to change without notice. Illustrations and photos show the standard models, and may or may not include optional equipment, accessories, and all standard equipment with some differences in colour and features. Before use, read and understand the Operator's Manual for proper operation.

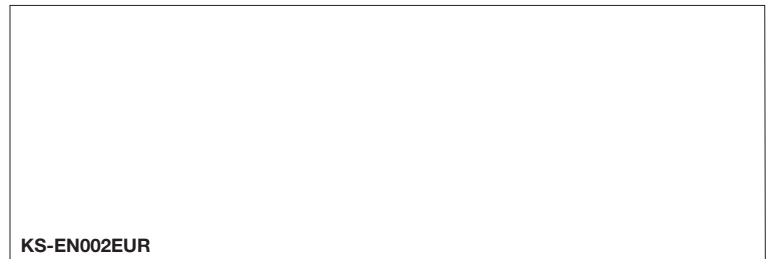

KS-EN002EUR