

ZAXIS-2 series

HITACHI

ZAXIS
22U



HYDRAULIC EXCAVATOR

- Model Code : ZX22U-2
- Engine Rated Power : 14.6 kW (19.9 PS)
- Operating Weight : 2 210 kg
- Backhoe Bucket : 0.07 m³

Hitachi applied all its excavator expertise in the design of the new zero-tail mini excavators ZAXIS 22U. This machine meets customer demands for operating comfort, enhanced safety and easier maintenance. The series complies with the latest emission regulations, noise suppression standards and ROPS/FOPS standards. Operators have superior control over the machine from the comfortable seat. Owners enjoy a lower cost of ownership due to the machine's durability and easy maintenance.



Note: Some of the pictures in this brochure show an unmanned machine with attachments in an operating position. These were taken for demonstration purposes only and the actions shown are not recommended under normal operating conditions.

Compact yet Powerful



Single Swing Pin
A single large swing pin is used to eliminate jerking.



Two Travel Speeds Provided
Two different travel speeds are available, making transport of the machine through the jobsite more efficient and smooth.

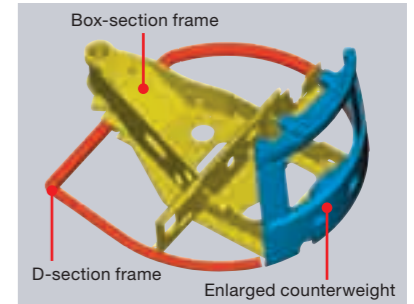

Enlarged Counterweight and Weighted Undercarriage
The newly developed box-section frame is adopted, combining low weight and high durability. The enlarged counterweight and weighted undercarriage help lower the center of gravity and increase stability.



Additional Counterweight (Optional)
When using a heavy front attachment such as a fork grapple, the additional counterweight is easily mounted for higher stability.

• Additional counterweight: 180 kg

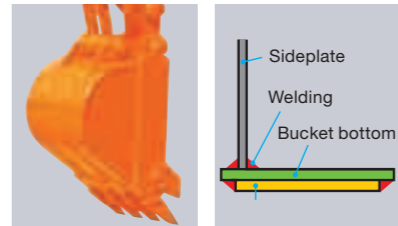

Durable Flat-Bottom Bucket
The flat-bottom bucket is provided standard to minimize bucket bottom wear. Wide wear plates are welded to the bucket bottom for increased durability.



Job-Proven HN Bushings
The field-proven HN bushing, a Hitachi original, is utilized at each front pin joint to reduce jerking and servicing. Lubricating interval is a long 500 hours

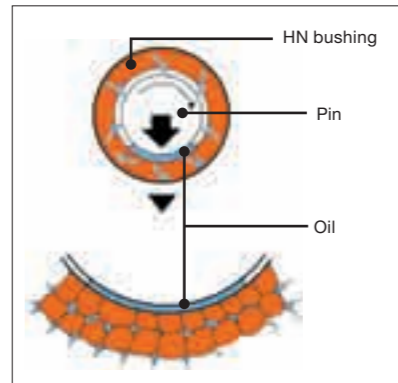

The HN bushing, another example of innovative technology developed by Hitachi, features long life and high durability. High-viscosity oil is vacuum impregnated in sintered high-hardness metal. During operation oil oozes from the pores of the bushing into the clearance between pin and bushing for self-lubrication.

Suitable for a Variety of Applications

- 2-side reinforced arm
- 4-side reinforced arm

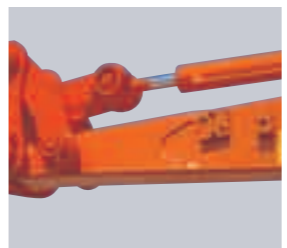

- NS (New Standard) key



- TEN key lock



- Pad crawler shoes





Operator Comfort and Safety



Easy-to-Read Monitor
The operator can always check machine conditions at a glance. Fuel level, coolant temperature and the status of various other indicators are clearly displayed in the right position.

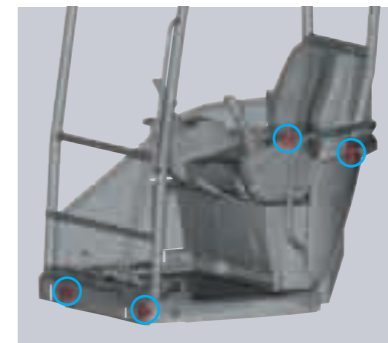

Rubber Mounted Floor
The cabin rests on 4 shock-absorbing rubber mounts to ensure comfortable operation.

Miscellaneous Devices

- Seat backrest box
- Drink holder



- Seat belt
- Ashtray (cabin)

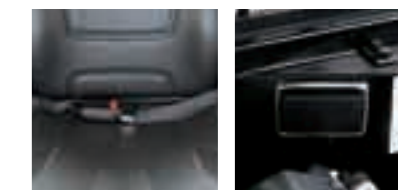

- Tool box (canopy)
- Slip-resistant tape



Improved Visibility with Roof Sun Visor (Canopy)
The Sun visor, an integral part of the roof, gives better upward visibility. The overhang roof keeps the operator's knees dry in light rain.



ROPS/FOPS Cabin and Canopy
Both canopy and cabin conform to the latest ROPS, FOPS and TOPS standards. These protect the operator in case of roll-over; tip-over and from falling objects. The seat belt protects the operator as well. The operator's cabin and canopy, complying with the international standards, are mounted to protect the operator in the case of tipping.

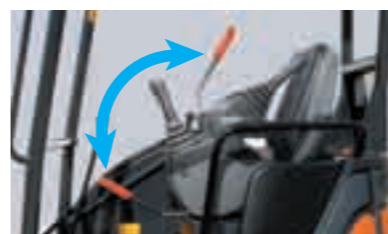

Pilot-Control Shut-Off Lever
All operations—front, swing, travel and blade—can be shut off by locking the pilot control shutoff valve. This effectively prevents accidental lever control.

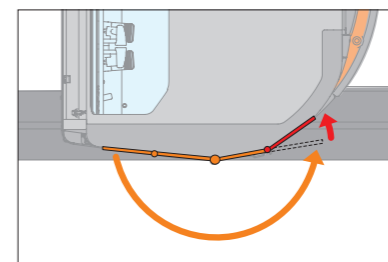

Neutral Engine Start System
The engine can start only when the pilot control shutoff lever is locked. This is called the neutral engine start system. This eliminates unexpected lurching when the engine suddenly starts when unconsciously touching the control lever.

Folded Large Cabin Door
The door opens in two steps and has increased width of 610 mm, allowing easy entry.

Swing/Travel Parking Brakes (Standard)
The swing parking brake and travel parking brake are both provided standard for enhanced safety.



Easy Maintenance



Tilt-Up Floor

The cabin floor can be tilted up for easy, quick servicing even in the case of an emergency. The floor can be tilted up to 50° to allow the operator to work under the cabin floor. It also gives direct access to the swing mechanism and starter motor behind the engine located under the cabin floor. This design reduces inspection and maintenance time.

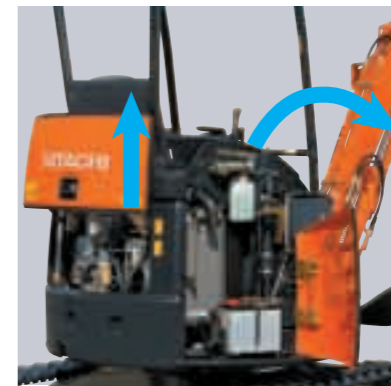

Simplified Daily Maintenance

The engine cover can slide up and down for quick servicing even in confined space. No more swing-open cover that obstructs maintenance and servicing jobs. The right side cover swings open for a quick battery and radiator check.



Uses Tracks Promoting Easy Mud Removal

The X-beam track frame is smooth for mud removal. One-sided slope on the side track frame promotes mud sliding off, minimizing mud packing problem. This shortens machine washing time and reduces disposal costs, too.



Reinforced D-Shaped Frame

The machine frame is reinforced with a D-shaped frame that protects against damage and impact by obstructions.



Split-Type Front Hoses

Split-type front hoses are jointed at the machine cover ports and the back of the boom for easy replacement.



Easy to Repair Steel Cover

A steel cover is utilized for tough operation, allowing easy repair if damaged. The steel cover is durable, recyclable and economical.



Parts and Service

Over the years Hitachi gained experience in one of the most competitive service markets in the world: Japan. Using our know-how in dealing directly with customers, we have created a worldwide support system that is highly effective and efficient. More than 150 dealers all over the world have highly trained technicians and high parts availability. Contact your Hitachi dealer for detailed information about service programs available for your area and machine. Not all services and/or programs are available in every region or for all machines.

To get the most out of your machine, you need genuine Hitachi parts. In most cases there is a Hitachi dealer in your area that has the required part in stock. Hitachi minimizes the delivery time for any part by connecting its 4 parts depots in Japan, Singapore, The Netherlands and North America by a on-line system sharing information on the number and type of available parts. In this way you are ensured that your parts are shipped as efficiently and quickly as possible.

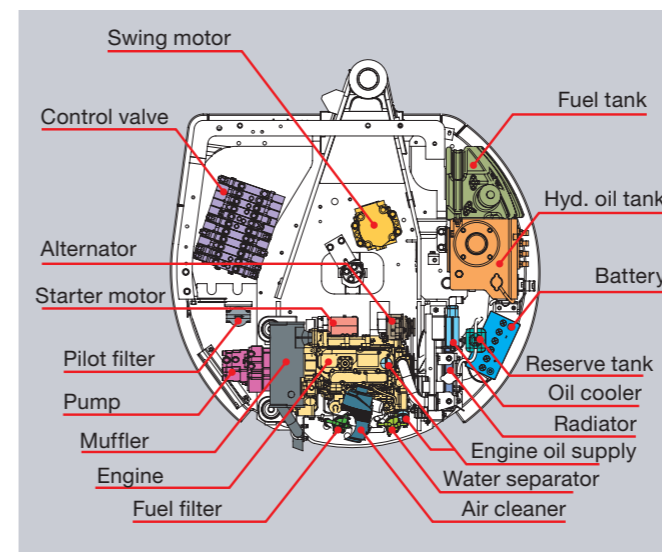

The ZX22U-2 share the same device layout for easy, efficient inspection and replacement. Inspection points are concentrated for quick daily maintenance.

ENGINE

Model	Yanmar 3TNV76
Type	Water-cooled, 4-cycle, 3-cylinder swirl combustion chamber injection type diesel engine
Rated power	
ISO 9249, net	14.6 kW (19.9 PS) at 2 400 min ⁻¹ (rpm)
Maximum torque	66 N·m (6.7 kgf·m) at 1 800 min ⁻¹ (rpm)
Bore & Stroke	76 x 82 mm
Piston displacement ..	1.115 L
Battery	1 x 12 V, 36 Ah

HYDRAULIC SYSTEM

The proven 3-pump system and arm regenerative circuit have been improved to make combined operations and fine control easier and smoother.

Main pumps	Two variable displacement axial piston pumps
Maximum oil flow	2 x 28.8 L/min
Third pumps	One gear pump
Maximum oil flow	15.6 L/min
Pilot pump	One gear pump
Maximum oil flow	6.5 L/min

Relief Valve Settings

Main pumps circuit	20.6 MPa (210 kgf/cm ²)
Third pump circuit	20.6 MPa (210 kgf/cm ²)
Pilot circuit	3.9 MPa (40 kgf/cm ²)

Hydraulic Cylinders

High-strength piston rods and tubes. Cylinder cushion mechanisms provided in boom raise and arm roll-in circuits to absorb shocks at stroke ends.

Dimensions

	Quantity	Bore	Rod diameter	Stroke
Boom Canopy	1	70 mm	40 mm	524 mm
Boom Cabin	1	70 mm	40 mm	509 mm
Arm	1	70 mm	40 mm	380 mm
Bucket	1	55 mm	35 mm	439 mm
Boom swing	1	65 mm	35 mm	372 mm
Blade	1	70 mm	40 mm	131 mm

CONTROLS

Hydraulic pilot control levers for all operations.

BACKHOE ATTACHMENTS

BUCKETS

ISO 7451 capacity	Width		No. of teeth	Weight	Front Attachment	
	Without side cutters	With side cutters			1.00 m arm	1.30 m arm
0.04 m ³	250 mm	300 mm	3	52 kg	A	A
0.05 m ³	300 mm	350 mm	3	53 kg	A	A
0.06 m ³	350 mm	400 mm	3	55 kg	A	A
0.07 m ³	400 mm	450 mm	3	58 kg	A	B
0.08 m ³	450 mm	500 mm	3	61 kg	B	B
0.09 m ³	500 mm	550 mm	4	66 kg	B	C
Arm crowd force					12.0 kN	10.0 kN
Bucket digging force					18.6 kN	18.6 kN

A : General digging B : Light-duty digging C : Loading

SWING MECHANISM

High-torque, axial piston motor with planetary reduction gear. Swing circle is single-row, shear-type ball bearing with induction-hardened internal gear. Internal gear and pinion are immersed in lubricant. Swing parking brake is spring-set/hydraulic-released disc type. Swing shockless valve built in swing motor absorbs shocks when stopping swing, ensuring smooth stops.

Swing speed	9.7 min ⁻¹ (9.7 rpm)
-------------------	---------------------------------

UNDERCARRIAGE

Tracks

Tractor-type undercarriage. Welded track frame using carefully selected materials. Side frame welded to track frame.

Numbers of Rollers on Each Side

Lower rollers	3
---------------------	---

Travel Device

Each track driven by a high-torque, 2-speed axial piston motor through planetary reduction gear, allowing counter-rotation of the tracks. Travel shockless relief valve built in travel motor absorbs shocks when stopping travel, ensuring smooth stops.

Travel speeds	High : 0 to 4.4 km/h
(with rubber shoes)	Low : 0 to 2.7 km/h
Travel speeds	High : 0 to 4.2 km/h
(with grouser shoes)	Low : 0 to 2.6 km/h

Gradeability	58 % (30 degree) continuous
--------------------	-----------------------------

WEIGHTS AND GROUND PRESSURE

Equipped with 1.00 m arm and 0.07 m³ (ISO 7451 capacity) bucket.

	Operating weight	Ground pressure
Canopy version		
250 mm rubber shoes	2 210 kg	26 kPa (0.26 kgf/cm ²)
250 mm grouser shoes	2 360 kg	28 kPa (0.28 kgf/cm ²)
Cabin version		
250 mm rubber shoes	2 350 kg	28 kPa (0.28 kgf/cm ²)
250 mm grouser shoes	2 500 kg	29 kPa (0.30 kgf/cm ²)

SERVICE REFILL CAPACITIES

	liters
Fuel tank	29.0
Engine coolant	4.3
Engine oil	3.8
Travel device (each side)	0.3
Hydraulic system	38.0
Hydraulic oil tank (Reference oil level)	28.0

DIMENSIONS

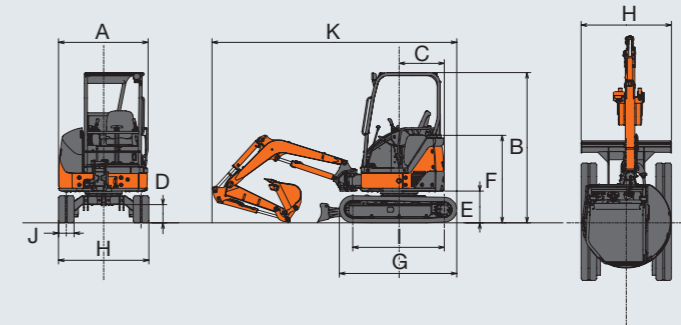

Note:

The illustration shows the ZX22U-2 canopy version equipped with 1.00 m arm and 250 mm rubber shoes. The canopy and cabin conform to ROPS (ISO 3471) and OPG (ISO 10262, Level 1) requirements.

Unit: mm

Model code	ZX22U-2	
	Canopy	Cabin
A Overall width	1 440	
B Overall height	2 410	2 460
C Rear-end swing radius (With Additional counterweight)	725 (820)	
D Minimum ground clearance	295	
E Counterweight clearance	510	
F Engine cover height	1 405	
G Undercarriage length	1 890	
H Undercarriage width	1 450	
I Sprocket centre to idler centre	1 470	
J Track shoe width	250	
K Maximum transport length (With 1.30 m arm)	3 930 (3 970)	

WORKING RANGES

Unit: mm

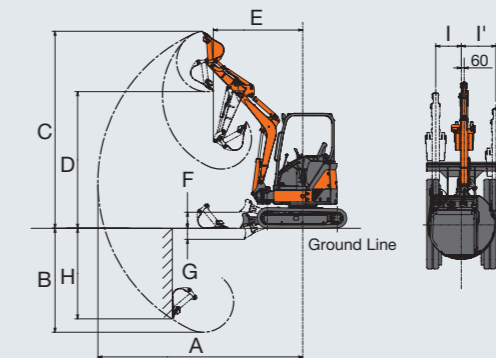

Note:

The illustration shows the ZX22U-2 canopy version equipped with 0.07 m³ bucket, 1.00 m arm and 250 mm rubber shoes.

Unit: mm

Model code	ZX22U-2	
	Canopy	Cabin
A Maximum digging reach	4 300 [4 580]	
B Maximum digging depth	2 320 [2 585]	
C Maximum cutting height	4 140 [4 350]	3 960 [4 150]
D Maximum dumping height	2 870 [3 080]	2 710 [2 900]
E Minimum swing radius (At maximum boom swing)	1 880 (1 570) [2 000 (1 675)]	1 975 (1 660) [2 060 (1 740)]
F Blade bottom highest position above ground	315	
G Blade bottom lowest position above ground	250	
H Maximum vertical wall	1 930 [2 210]	
I / I' Offset distance (Maximum boom-swing angle)	515 (48°) / 710 (67°)	

The figure in [] shows the equipped with 1.30 m arm.

Metric measure

- Notes: 1. Ratings are based on ISO 10567.
 2. Lifting capacity does not exceed 75 % of tipping load with the machine on firm, level ground or 87 % full hydraulic capacity.
 3. The load point is the center-line of the bucket pivot mounting pin on the arm.
 4. An asterisk mark (*) indicates load limited by hydraulic capacity.

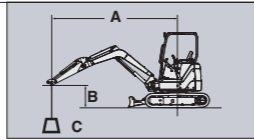

A: Load radius
 B: Load point height
 C: Lifting capacity

ZX22U-2 CANOPY VERSION, BLADE ABOVE GROUND

Unit : 1 000 kg

Conditions	Load point height	Load radius						At max. reach		
		1.0 m		2.0 m		3.0 m		meter		
		⊕	⊖	⊕	⊖	⊕	⊖			
Arm 1.00 m Rubber shoes 250 mm	2.0 m			0.66	*0.69	0.34	0.40	0.27	0.32	3.47
	1.0 m					0.32	0.38	0.24	0.28	3.66
	0 (Ground)			0.56	0.69	0.31	0.37	0.25	0.30	3.49
	-1.0 m	*1.62	*1.62	0.57	0.70			0.34	0.41	2.85

Conditions	Load point height	Load radius						At max. reach		
		1.0 m		2.0 m		3.0 m		meter		
		⊕	⊖	⊕	⊖	⊕	⊖			
Arm 1.00 m Rubber shoes 250 mm Extra counterweight 180kg	2.0 m			*0.69	*0.69	0.41	0.48	0.32	0.38	3.47
	1.0 m					0.39	0.46	0.29	0.34	3.66
	0 (Ground)			0.67	0.82	0.37	0.44	0.31	0.36	3.49
	-1.0 m	*1.62	*1.62	0.68	0.83			0.41	0.48	2.85

ZX22U-2 CANOPY VERSION, BLADE ON GROUND

Unit : 1 000 kg

Conditions	Load point height	Load radius						At max. reach		
		1.0 m		2.0 m		3.0 m		meter		
		⊕	⊖	⊕	⊖	⊕	⊖			
Arm 1.00 m Rubber shoes 250 mm	2.0 m			0.66	*0.69	0.34	*0.59	0.27	*0.59	3.47
	1.0 m					0.32	*0.74	0.24	*0.61	3.66
	0 (Ground)			0.56	*1.51	0.31	*0.83	0.25	*0.65	3.49
	-1.0 m	*1.62	*1.62	0.57	*1.21			0.34	*0.68	2.85

Conditions	Load point height	Load radius						At max. reach		
		1.0 m		2.0 m		3.0 m		meter		
		⊕	⊖	⊕	⊖	⊕	⊖			
Arm 1.00 m Rubber shoes 250 mm Extra counterweight 180kg	2.0 m			*0.69	*0.69	0.41	*0.59	0.32	*0.59	3.47
	1.0 m					0.39	*0.74	0.29	*0.61	3.66
	0 (Ground)			0.67	*1.51	0.37	*0.83	0.31	*0.65	3.49
	-1.0 m	*1.62	*1.62	0.68	*1.21			0.41	*0.68	2.85

ZX22U-2 CANOPY VERSION, BLADE ABOVE GROUND, 1.30 m ARM

Unit : 1 000 kg

Conditions	Load point height	Load radius						At max. reach		
		1.0 m		2.0 m		3.0 m		meter		
		⊕	⊖	⊕	⊖	⊕	⊖			
Arm 1.30 m Rubber shoes 250 mm	2.0 m					0.35	0.41	0.23	0.28	3.78
	1.0 m			0.59	0.73	0.32	0.38	0.21	0.25	3.96
	0 (Ground)			0.55	0.68	0.31	0.37	0.22	0.26	3.80
	-1.0 m	*1.20	*1.20	0.55	0.68	0.30	0.36	0.28	0.33	3.25

Conditions	Load point height	Load radius						At max. reach		
		1.0 m		2.0 m		3.0 m		meter		
		⊕	⊖	⊕	⊖	⊕	⊖			
Arm 1.30 m Rubber shoes 250 mm Extra counterweight 180kg	2.0 m					0.41	0.48	0.28	0.33	3.78
	1.0 m			0.70	0.86	0.39	0.46	0.26	0.30	3.96
	0 (Ground)			0.66	0.81	0.37	0.44	0.27	0.31	3.80
	-1.0 m	*1.20	*1.20	0.66	0.81	0.37	0.44	0.33	0.39	3.25

ZX22U-2 CANOPY VERSION, BLADE ON GROUND, 1.30 m ARM

Unit : 1 000 kg

Conditions	Load point height	Load radius						At max. reach		
		1.0 m		2.0 m		3.0 m		meter		
		⊕	⊖	⊕	⊖	⊕	⊖			
Arm 1.30 m Rubber shoes 250 mm	2.0 m					0.35	*0.50	0.23	*0.43	3.78
	1.0 m			0.59	*1.22	0.32	*0.67	0.21	*0.45	3.96
	0 (Ground)			0.55	*1.45	0.31	*0.81	0.22	*0.53	3.80
	-1.0 m	*1.20	*1.20	0.55	*1.38	0.30	*0.73	0.28	*0.61	3.25

Conditions	Load point height	Load radius						At max. reach		
		1.0 m		2.0 m		3.0 m		meter		
		⊕	⊖	⊕	⊖	⊕	⊖			
Arm 1.30 m Rubber shoes 250 mm Extra counterweight 180kg	2.0 m					0.41	*0.50	0.28	*0.43	3.78
	1.0 m			0.70	*1.22	0.39	*0.67	0.26	*0.45	3.96
	0 (Ground)			0.66	*1.45	0.37	*0.81	0.27	*0.53	3.80
	-1.0 m	*1.20	*1.20	0.66	*1.38	0.37	*0.73	0.33	*0.61	3.25

STANDARD EQUIPMENT

Standard equipment may vary by country, so please consult your Hitachi dealer for details.

ENGINE

- Water-separator for engine fuel system
- Neutral engine start system

HYDRAULIC SYSTEM

- Hydraulic pilot type control levers
- Pilot control shut-off lever
- Two-speed travel system
- Swing parking brake
- Travel parking brake
- Piping for attachments

CANOPY (CABIN)

- ROPS/FOPS**
- Adjustable reclining seat**
- Seat belt**
- Seat backrest box**
- Windshield wiper***
- Windshield washer***
- Two work lights**
- AM/FM radio***
- Ashtray***
- Drink holder**
- Utility box*
- Evacuation hammer***
- Tool box*
- Slip-resistant tape**

UNDERCARRIAGE

- 250 mm rubber shoes
- Semi-long stay blade

FRONT ATTACHMENTS

- O-ring type pin-seals for hoe bucket
- HN bushing
- 1.88 m boom
- 1.00 m arm

Notes:

- * For canopy versions
- ** For canopy and cabin versions
- ***For cabin versions

OPTIONAL EQUIPMENT

Optional equipment may vary by country, so please consult your Hitachi dealer for details.

ENGINE

- Air cleaner double filter

HYDRAULIC SYSTEM

- Travel motion alarm device

CANOPY (CABIN)

- Suspension seat**
- Wrist rest**
- 12 V outlet**
- Auxiliary light**
- Rear view mirror**
- NS (New Standard) key**
- Electrical key (Immobilizer)**
- TEN key lock**
- Mechanical lock**

UNDERCARRIAGE

- 250 mm grouser shoes
- 250 mm pad crawler shoes

FRONT

- 1.30 m arm
- Backhoe buckets

COUNTERWEIGHT

- Additional counterweight : 180 kg

Notes:

- * For canopy versions
- ** For canopy and cabin versions
- ***For cabin versions

These specifications are subject to change without notice.
Illustrations and photos show the standard models, and may or may not include optional equipment, accessories, and all standard equipment with some differences in colour and features.
Before use, read and understand the Operator's Manual for proper operation.

